

FORD:

2005-2009 Mustang

ISSUE

Some 2005-2009 Mustang vehicles may exhibit a rattle noise where the A-pillar meets the dash area. This rattle may be due to worn, missing or off location tape under the dash panel and/or A-pillar dual lock (velcro) fastener(s) not seated.

ACTION

Follow the Service Procedure steps to correct the condition.

SERVICE PROCEDURE**NOTE**

DASH INSULATOR WAS EXTENDED UNDER THIS AREA FOR 2008 AND 2009 VEHICLES. (FIGURE 1) FOR 2005-2007 VEHICLES MULTIPLE VARIETIES OF TAPE WERE USED UNDER THIS AREA. (FIGURE 2)

1. Remove A-pillar trim.
2. Inspect for tape under flanged edge of dash panel. If tape is missing or damaged, then add or replace with improved tape. This tape has a plastic top coating to protect the felt tape from wear. Install felt tape with adhesive side down. (Figures 1-2)

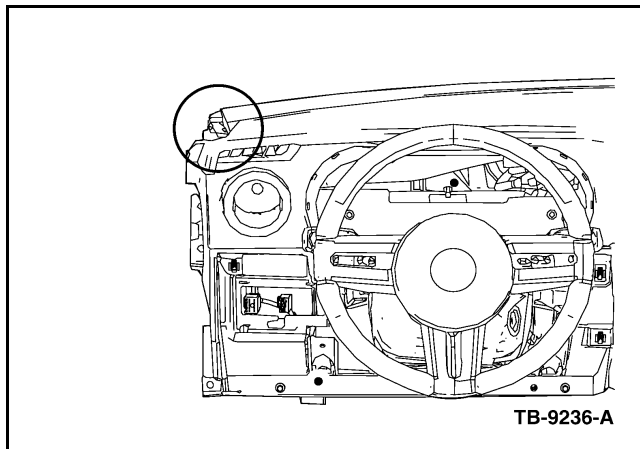

TB-9236-A

Figure 1 - Article 08-24-10

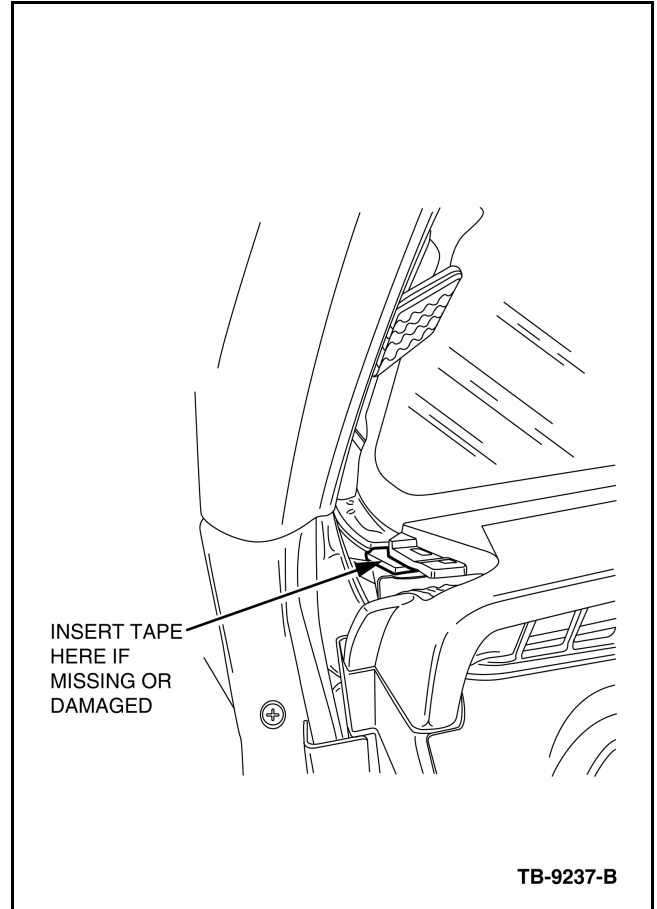

TB-9237-B

Figure 2 - Article 08-24-10

3. Attach tape to end of screwdriver. (Figure 3) Insert under dash panel flange with plastic side of tape up. (Figure 4) Press down on dash panel to secure adhesive. Hold pressure on dash while removing screwdriver.

NOTE: The information in Technical Service Bulletins is intended for use by trained, professional technicians with the knowledge, tools, and equipment to do the job properly and safely. It informs these technicians of conditions that may occur on some vehicles, or provides information that could assist in proper vehicle service. The procedures should not be performed by "do-it-yourselfers". Do not assume that a condition described affects your car or truck. Contact a Ford, Lincoln, or Mercury dealership to determine whether the Bulletin applies to your vehicle. Warranty Policy and Extended Service Plan documentation determine Warranty and/or Extended Service Plan coverage unless stated otherwise in the TSB article. The information in this Technical Service Bulletin (TSB) was current at the time of printing. Ford Motor Company reserves the right to supersede this information with updates. The most recent information is available through Ford Motor Company's on-line technical resources.

TSB 08-24-10 (Continued)

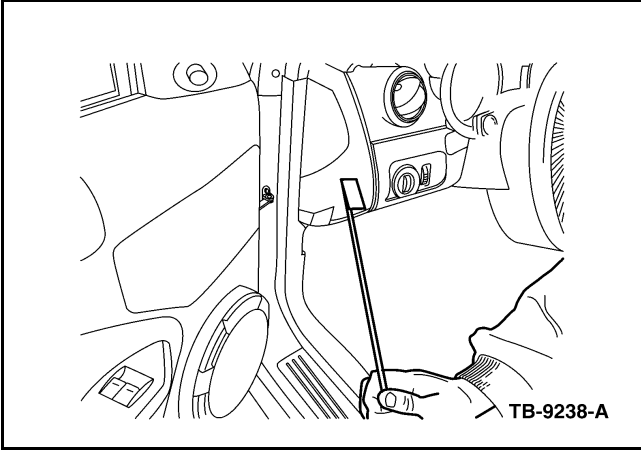

Figure 3 - Article 08-24-10

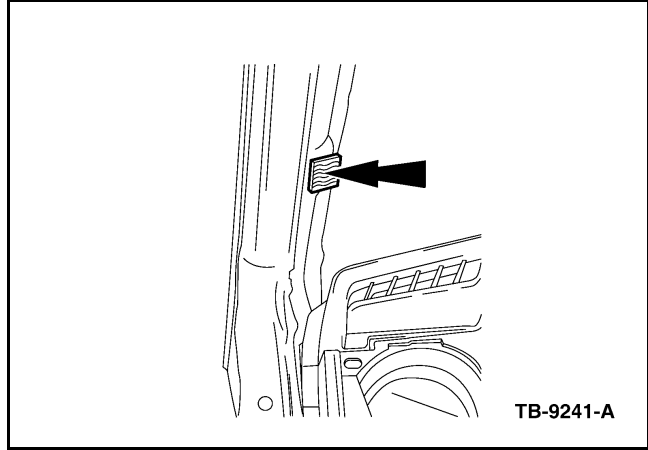

Figure 6 - Article 08-24-10

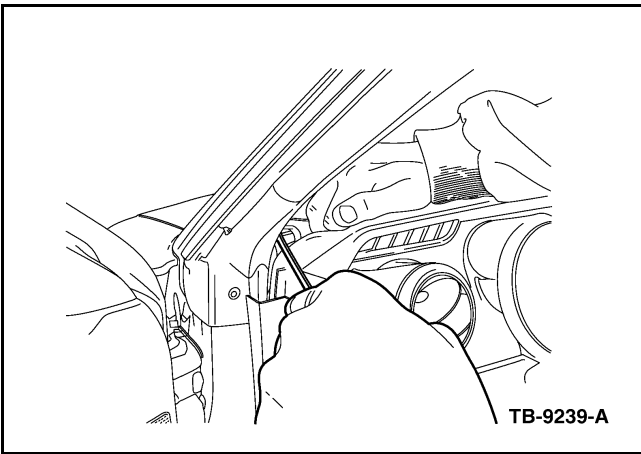

Figure 4 - Article 08-24-10

4. Inspect both A-pillar trim and A-pillar sheet metal to make sure both dual lock (velcro) fasteners are present. Replace if missing. (Figures 5-6)

5. Install A-pillar. Press to securely mate dual lock fastener. (Figure 7)

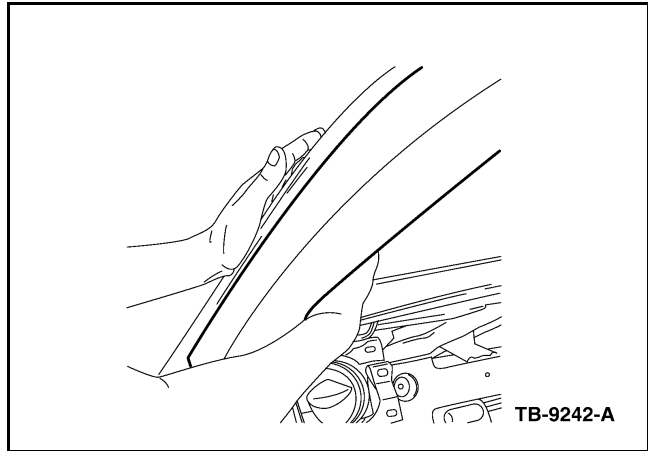

Figure 7 - Article 08-24-10

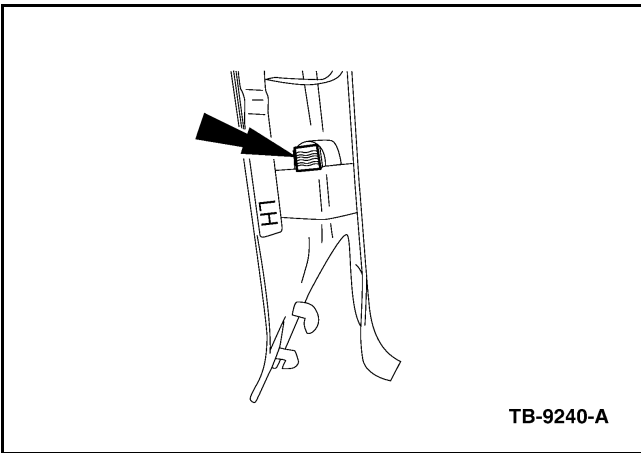

Figure 5 - Article 08-24-10

PART NUMBER	PART NAME
7R3Z-6321702-A	Felt Tape
5R3Z-6303552-AA	Dual Lock - Sheet Metal
W790192-S900	Dual Lock - A-Pillar Fasteners

WARRANTY STATUS: Eligible Under Provisions Of New Vehicle Limited Warranty Coverage
IMPORTANT: Warranty coverage limits/policies are not altered by a TSB. Warranty coverage limits are determined by the identified causal part.

OPERATION	DESCRIPTION	TIME
082410A	2005-2009 Mustang: Secure A-Pillar Trim Following Service Procedure ONE SIDE (Do Not Use With 04104A)	0.3 Hr.

082410B 2005-2009 Mustang: 0.4 Hr.
 Secure A-Pillar Trim
 Following Service
 Procedure BOTH SIDES
 (Do Not Use With 04104A)

DEALER CODING

BASIC PART NO.	CONDITION CODE
6303598	25