



---

Instructions for  
**Trick Flow EFI Fuel Rail Kit**  
**TFS-51580001**

---

**CAUTION:**

Installation of this product requires detailed knowledge of automotive systems and repair procedures. We recommend that this installation be carried out by a qualified automotive technician.

Installation of this product requires handling of gasoline. Ensure you are working in a well ventilated area with an approved fire extinguisher nearby.

Extinguish all open flames, prohibit smoking and eliminate all sources of ignition in the area of the vehicle before proceeding with the installation.

When installing this product, wear eye goggles and other safety apparel as needed to protect you from debris and sprayed gasoline.

**WARNING:**

The fuel system is under pressure. Do not open the fuel system until the pressure has been relieved. Refer to the appropriate vehicle service manual for the procedure and precautions for relieving the fuel system pressure.

NOTE: Testing the enclosed regulator by applying air pressure or vacuum to the vacuum port with a hand-held pump will yield poor results, due to the slight air leakage through the adjustment screw threads. This minute leakage, which is typical of all adjustable fuel pressure regulators, does not, in any way, affect the performance of the regulator. The enclosed fuel pressure regulator may not hold significant fuel pressure after the fuel pump stops running.

The enclosed Trick Flow Specialties regulator utilizes two o-ring sealed AN-10 style inlet/outlet ports and one o-ring sealed AN-6 style bypass port; these regulator ports are NOT PIPE THREAD and utilize NO THREAD SEALANT. To use the enclosed regulator in your vehicle's fuel system, you must install the necessary adapter fittings and o-rings, high pressure fuel lines and/or fuel injector rails to adapt your system to the configuration and ports of this regulator. The following instructions assume that your fuel system has already been configured for use with this regulator.

Trick Flow Specialties' system components are not legal for sale or use on emission controlled motor vehicles.

The following steps are typical of most installations:

1. Once the engine has been allowed to cool, disconnect the negative battery cable and relieve the fuel system pressure, referring to the appropriate vehicle service manual for the procedure on doing so.
2. Remove the air intake ducting from the throttle body and position it out of the way.
3. Note the location of and remove any vacuum lines connected to the upper intake manifold and position them out of the way.
4. Remove the throttle cable from the throttle body; referring to the appropriate vehicle service manual for the procedure for doing so.
5. Unplug the TPS sensor, which is typically located on top of the throttle body.
6. Remove the nameplate on the top of the upper intake manifold by removing 4 screws.
7. Remove the upper intake manifold bolts (Typically there are 6 of them).
8. Gently remove the upper intake from the engine. Place clean shop towels into or tape up the lower intake ports to prevent any material from entering the intake.
9. Carefully clean the old gasket material from both manifolds, while preventing any debris from entering the intake manifold ports.
10. Check for any dirt or debris around the fuel injectors. If any is evident, wash it off with some solvent parts cleaner or wipe it off with a clean shop towel.
11. Disconnect the electrical connector at each injector, making note of the location of each.
12. Disconnect both the supply and return fuel lines from the OEM fuel rails. These lines are attached by a special quick disconnect fitting which requires a special tool for removal. Place clean shop towels around the open fuel lines to catch any gasoline that may drip out and to prevent any dirt from entering the fuel lines.
13. Remove any cosmetic covers necessary to allow access to the fuel pressure regulator.
14. Remove the vacuum line from the regulator.
15. Remove the bolts that attach the fuel rail to the lower intake (Typically there are 4 of them).
16. Place clean shop towels around the injectors to catch any gasoline that may be spilled during their removal. Remove the injectors from the manifold by gently pulling upward on the fuel rail / injector assembly. Keep all injectors connected to the fuel rails. If an injector does pull out of the fuel rail, it may spill a large amount of fuel.
17. Carefully remove the fuel injectors from the OEM fuel rail.
18. Remove the old o-rings from the fuel injectors, inspect the injectors for any dirt or debris and clean if needed. It is suggested that the old o-rings be replaced, contact your local Ford parts dept.
19. Coat the new fuel injector o-rings with a light oil to ease installation.
20. Carefully install the new fuel injector o-rings on the injectors.

21. Place a thin coat of light oil in the fuel rail fuel injector bores and in the lower intake manifold injector bores to help prevent cutting the o-rings during installation.

22. Carefully place the fuel injectors in the fuel rails. Position the electrical connector on each fuel injector to the opposite side of the fuel rail as the mounting bracket.

23. Install the fuel rail that has an AN-08 port plug in one end on the driver side, with the port plug facing the front of the vehicle. This kit comes with 2 aluminum spacers which get installed between the lower intake manifold and the fuel rail brackets. In some instances it will be required to install additional flat washers to space the rail out further from the distributor. After insuring that the injectors are properly seated in the intake manifold injector bores, install the driver side fuel rail mounting bolts, insuring that the fuel rail spacers are captured between the fuel rail bracket and the lower intake manifold.

24. Install the passenger side fuel rail; being careful not to cut any of the o-rings during installation (This fuel rail does not require any spacers between the fuel rail bracket and the lower intake).

25. Place shop towels around the regulator to catch any gasoline that is spilled during this step of the installation. Remove any regulator mounting hardware and connecting fuel lines, and then carefully remove the regulator.

26. Find a suitable place in the vehicle's engine compartment to mount the Trick Flow Specialties' regulator. Mark the bracket mounting holes using the supplied mounting bracket as a template, and drill to accept a #10 screw.

27. With the bracket attached to the regulator, mount the bracket and regulator to the vehicle using two #10 screws, nuts and lock washers.

28. Attach the fuel line(s) from the fuel rail outlet port(s) to the regulator **side** ports using AN-10 style fittings and o-rings. If only one fuel supply line is used, install an AN-10 style plug and o-ring into the second regulator inlet port.

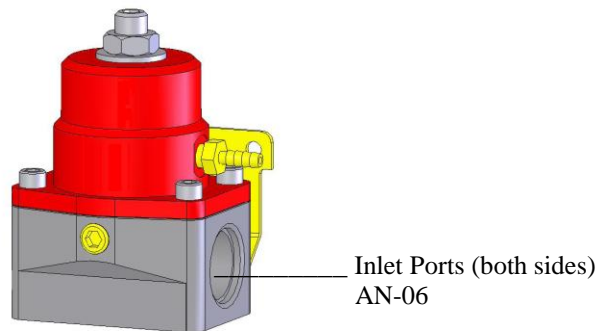

29. Attach the fuel return line to the regulator **bottom** port using an AN-6 style fitting and o-ring.

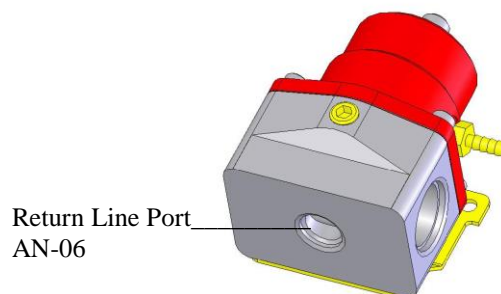

30. Install one AN-08 o-ring on each of the two AN-08 union fittings

31. Install on AN-08 o-ring on the AN-08 cutoff side of each of the two AN-08/AN-6 reducer unions.
32. Thread the o-ring side of each two AN-08 unions in the back of each fuel rail.
33. Thread the o-ring side of one of the AN-08/AN-06 reducer unions into the front of the passenger side fuel rail. Thread the remaining fitting into the bottom center of the driver side fuel rail.
34. Starting from the fuel rails, plan a route to run an AN-08 supply line from each fuel rail to each side of the regulator. Cut the two supply lines to the determined length and install the AN-08 hose ends.

**Note: Be sure to route all fuel lines clear of any moving suspension or drivetrain components and any exhaust components! Protect fuel lines from abrasion and road obstructions or debris.**

35. Using the above steel braided hose assemblies, connect one end to the side of the fuel pressure regulator and the other end to the fuel rails, and tighten.

**Please note if installing a high performance fuel pump, the OEM return line will be too restrictive to handle the volume of fuel that these pumps are capable of pumping. To prevent loosing lower pressure adjustability of your regulator it will be necessary to replace the OEM return line with a 3/8" ID (AN-06) return line in these cases.**

36. This kit contains one AN-06 straight hose end which will connect to the OEM fuel line adapter fitting and one AN-06 90 degree hose end, to connect to the AN-06 union on the bottom of the fuel pressure regulator. With these fittings in place, measure the length of fuel line needed and assemble the hose. (See section titled Hose and Fitting Assembly) Once the hose is assembled, **ensure there is no debris in the hose** and install it.

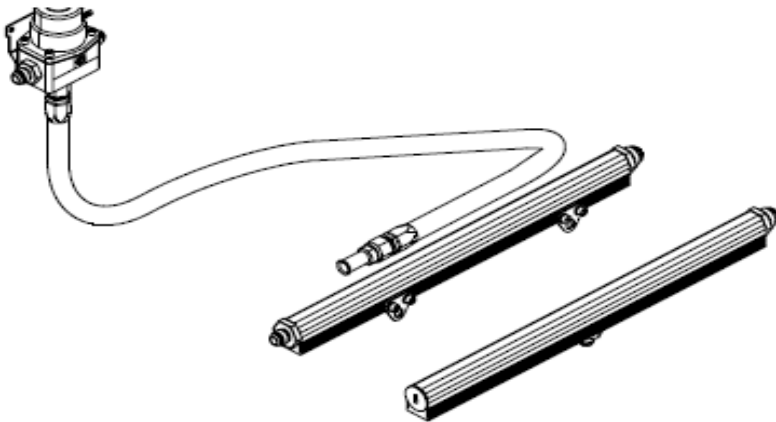

37. Connect one AN-06 straight hose end to each of the two ports on the fuel pressure regulator. Connect one AN-06 90-degree hose end to each of the AN-08/AN-06 reducer unions on the fuel rails. Plan a route for each of the two lines between the fuel pressure regulator and the fuel rails, measure the two lengths of fuel line needed. (See section titled Hose and Fitting Assembly) Once the hoses are assembled, **ensure there is no debris in the hose** and install them.

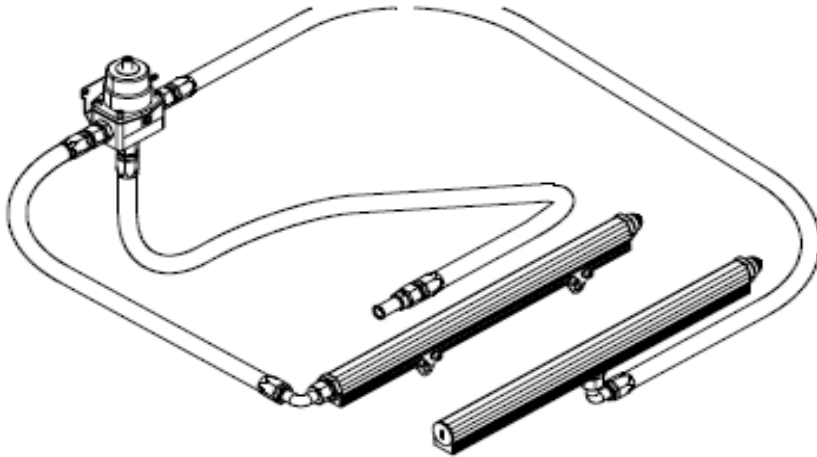

38. Inspect the OEM fuel supply line o-rings and replace if necessary. Place a light coat of oil on the fuel supply line o-rings and the supply line adapter fitting to ease installation. Connect the AN-08 tee adapter fitting to the OEM fuel supply line.

39. Using the remaining AN-08 hose end fittings as a guide, measure the required fuel line lengths needed and make up the last two required AN-08 fuel supply lines. (See section titled Hose and Fitting Assembly)

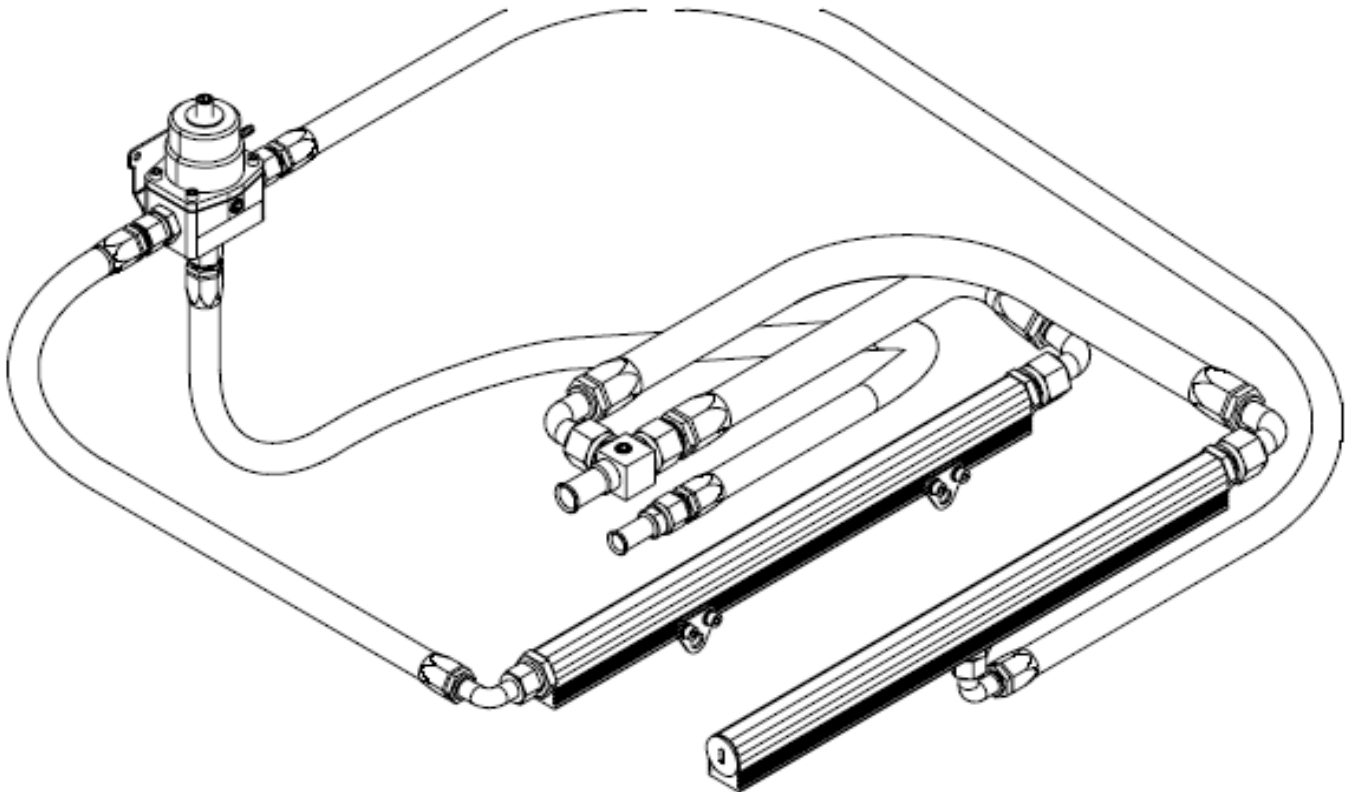

40. Reassemble the vehicle using the reverse of the foregoing removal procedure.

**Please note, due to the wide range of applications and varying OEM and after market component tolerances it has been found in a few isolated cases it is necessary to install a 3/8" thick spacer between the upper and lower intake manifolds. This will**

allow you to gain clearance between the top of the fuel rails and the bottom of the upper intake manifold. These spacers are readily available from Summit Racing Equipment.

41. Remove the 1/8 NPT pipe plug from the either the fuel pressure regulator or fuel supply adapter tee fitting and attach a suitable fuel pressure gauge.

**42. Ensure that any spilled gasoline and any gasoline soaked shop towels are cleaned up and removed from the vicinity of the vehicle!**

43. Reconnect the battery and turn the ignition to the ON position **WITHOUT** starting the car. After several seconds, check the fuel pressure. If there is no fuel pressure, turn the ignition key to the OFF position, wait one minute, return the ignition to the ON position, and recheck the fuel pressure. Repeat this ignition OFF and ON procedure until the fuel pressure gauge registers fuel pressure.

**44. With the fuel pressure gauge registering fuel system pressure, check for fuel leaks from and around the Trick Flow Specialties ' regulator, fuel rails, fuel lines and connections! If any fuel leaks are found, turn the ignition key to the OFF position, remove any spilled fuel and repair the leak before proceeding!**

45. Once the fuel pressure gauge registers fuel system pressure and there are no fuel leaks, start the engine and adjust the regulator to the desired fuel pressure. Turning the adjustment screw clockwise will increase fuel pressure. OEM regulators are typically set at approximately 43 psi, without the vacuum line attached. The fuel pressure adjustment range for this regulator is 35-75 psi and we recommend setting the static pressure (no vacuum) at 48 psi.

**Due to the confined nature of modern OEM vehicles Trick Flow realizes that the fuel pressure regulator may be inconvenient to adjust in some applications. We feel that this small inconvenience is worth it in providing you with an optimal fuel system.**

46. Once the desired fuel pressure is achieved, tighten the regulator adjustment jam nut and attach the vacuum line.

47. Turn off the engine and allow it to cool. If you do not want to keep the fuel pressure gauge on the vehicle, relieve the fuel system pressure as instructed in the appropriate vehicle service manual. Remove the fuel pressure gauge and reinstall the 1/8 NPT pipe plug, using thread sealant.

48. Test drive the car to insure proper operation and re-check the fuel system for leaks. **If any leaks are found, immediately shutoff the engine and repair the leak(s)!**

## Hose and Fitting Assembly

### CAUTION:

**When assembling this product, wear eye goggles and other safety apparel as needed to protect you from debris and sharp edges.**

A. Wrap hose with masking tape at desired cutoff length. Cut hose through masking tape squarely to desired length using a cut-off machine or a fine tooth hacksaw. Remove the masking tape.

B. Unthread the hose socket from the rest of the hose end fitting.

C. Insert hose in the socket with a twisting and pushing motion until the hose is fully seated in the socket.

- D. Using a grease pencil, marker or tape, mark the location of the hose in relation to the hose socket which you just installed.
- E. Using light oil lubricates the inside of the hose and the hose end mating parts.
- F. Carefully thread the hose end onto the hose socket, making sure that the hose does not push out of socket, by observing the mark you placed on the hose in step D.
- G. Using a properly sized wrench, complete threading the two components together (The maximum allowable gap between the two fitting components is .030 inches).
- H. Inspect the hose for push out by comparing the mark you made on the hose in step D to the hose end socket location.
- I. Clean all debris from exterior and interior of hose.
- J. All lines should be tested to twice their operation pressure prior to use.

## **Ultimate Bolt-On Performance® Lifetime Warranty**

**Trick Flow Specialties cylinder head castings are backed by a lifetime warranty. If a cylinder head casting fails to provide the original purchaser with complete satisfaction, Trick Flow Specialties will repair or replace it free of charge — guaranteed!**

Moreover, the valves, valve guides, valve seats, valve job, valve springs, valve spring retainers, valve locks, rocker arm studs, guideplates, and valve stem seals included on assembled Trick Flow Specialties cylinder heads are warranted to the original purchaser to be free from defects in materials and workmanship for a period of two years from the date of purchase. All other Trick Flow Specialties products are warranted to be free from defects in materials and workmanship for a period of 90 days. There are no mileage limitations.

### **Extent of Warranty**

Customers who believe they have a defective product should return it to the dealer from which they purchased or ship it freight prepaid to Trick Flow Specialties along with proof of purchase and a complete description of the problem. If a thorough inspection indicates defects in materials or workmanship, our sole obligation is to repair or replace the product.

This warranty is only if the product is properly installed, subjected to normal use and service, did not fail due to owner negligence or misuse, and has not been altered or modified.

Trick Flow Specialties warranties do not cover any installation or removal costs.

Trick Flow Specialties is not liable for consequential damages for breach of contract of any warranty in excess of the purchase price of the product sold.

### **PROPOSITION 65 WARNING**

This product may contain one or more substances or chemicals known to the state of California to cause cancer, birth defects or other reproductive harm.

TRICK FLOW SPECIALTIES  
285 WEST AVE.  
TALLMADGE, OHIO 44278  
(330) 630-1555

