



Instructions for Trick Flow SBF SPRING UPGRADE KIT TFS-2500100

Thank you for purchasing a Trick Flow Valve Spring Upgrade Kit. This kit contains higher rate valve springs and special retainers that will allow you to use a performance cam up to .542" lift on OEM cast iron heads without machining. The installation is quite simple and can be done without removing your cylinder heads.

To perform this operation with the heads on the engine, you will need a valve spring compressor, an air compressor and an adapter fitting to put compressed air into the cylinder. Don't forget your safety glasses.

Installation

1. Disconnect the negative battery cable.
2. Remove the valve cover from the head you will be working on. On EFI engines, it will be necessary to remove the upper plenum and throttle body before you can remove the valve cover.
3. Carefully remove the ignition wire boots from the spark plugs. If the wires are not marked with their cylinder number, label the wires as you remove them. Use an air gun to blow any debris away from the base of the spark plug (wear safety glasses for this step!). Remove the spark plugs, being careful not to get any contaminants into the cylinders.
4. Remove all of the rocker arms, pedestals and pushrods. Be sure to keep all parts in order so they can be put back in their original positions.
5. Install the adapter fitting into the first cylinder. Apply 85-100 psi of air pressure and manually turn over the engine until it stops. Keep hands clear of the fan and anything else that turns for this step! Manual transmission cars must be in neutral with the parking brake on; automatic transmissions should be in park.
6. Starting with either the intake or exhaust valve, tap the valve spring retainer with a brass hammer to loosen the retainer from the keepers. Be careful not to hit the valve stem!
7. Attach the valve spring compressor and compress the valve spring far enough to remove the keepers and the old spring. Use caution when compressing the valve spring since it will have a great deal of stored energy when it is compressed. Next, pry the old valve stem seal off of the valve guide.
8. Get the appropriate retainer from the kit for the valve you are working on. The intake retainers are labeled, the exhaust retainers are not. There are two different retainers, so do not mix them up. The different retainers give the intake and the exhaust different installed heights.
9. Install the proper retainers and keepers on the valve without a valve spring, then pull up tight on the retainer. Insert the supplied height gauge between the outer edge of the retainer and spring seat. The supplied gauge is 1.800" tall; correct installed height should be 1.800" \pm .015". Use the appropriate shim to adjust the installed height if needed.
10. After checking the installed height, remove the retainer and keepers but leave any shims in place. Slip the valve stem seal protector over the valve tip and lubricate the exposed length of the valve stem with clean motor oil. Install the new seal on the valve stem, sliding it down evenly until you can push it onto the valve guide.
11. Remove the seal protector, then install the new spring with the correct retainer. Repeat this process with the rest of the valves, making sure to follow the above directions exactly.
12. Reinstall the pushrods, pedestals and rocker arms back into their original positions and torque the pedestal bolts to 22 ft.-lbs. Reinstall the valve cover, spark plugs, and plug wires.
13. Repeat Steps 2 through 11 on the other cylinder head.
14. When the spring installation on both heads is complete, reinstall the EFI upper plenum and throttle body, if applicable. Check all vacuum lines, reconnect the negative battery cable and start the engine. Drive the vehicle easy for about one hour, then change the oil and oil filter.

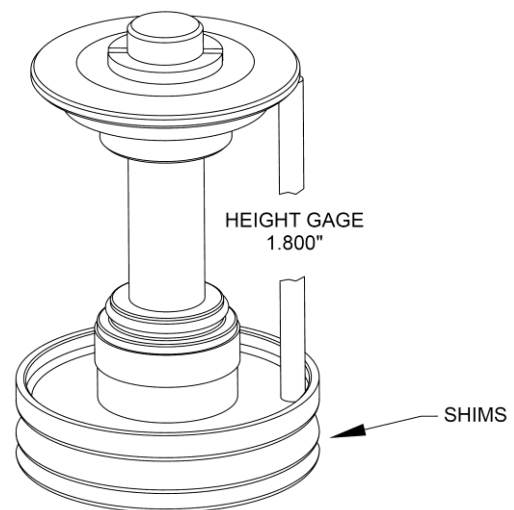

Ultimate Bolt-On Performance® Lifetime Warranty

Trick Flow Specialties cylinder head castings are backed by a lifetime warranty. If a cylinder head casting fails to provide the original purchaser with complete satisfaction, Trick Flow Specialties will repair or replace it free of charge — guaranteed!

Moreover, the valves, valve guides, valve seats, valve job, valve springs, valve spring retainers, valve locks, rocker arm studs, guideplates, and valve stem seals included on assembled Trick Flow Specialties cylinder heads are warranted to the original purchaser to be free from defects in materials and workmanship for a period of two years from the date of purchase. All other Trick Flow Specialties products are warranted to be free from defects in materials and workmanship for a period of 90 days. There are no mileage limitations.

Extent of Warranty

Customers who believe they have a defective product should return it to the dealer from which they purchased or ship it freight prepaid to Trick Flow Specialties along with proof of purchase and a complete description of the problem. If a thorough inspection indicates defects in materials or workmanship, our sole obligation is to repair or replace the product.

This warranty is only if the product is properly installed, subjected to normal use and service, did not fail due to owner negligence or misuse, and has not been altered or modified.

Trick Flow Specialties warranties do not cover any installation or removal costs.

Trick Flow Specialties is not liable for consequential damages for breach of contract of any warranty in excess of the purchase price of the product sold.

PROPOSITION 65 WARNING

This product may contain one or more substances or chemicals known to the state of California to cause cancer, birth defects or other reproductive harm.

TRICK FLOW SPECIALTIES
285 WEST AVE.
TALLMADGE, OHIO 44278
(330) 630-1555

