



Stiffening Rail Kit 1979-1993 Mustangs (SR-M02)

Installed behind the rocker panel pinch weld lip, these rails multi-task by adding strength and stiffness to your Mustang's chassis as well as providing a safe and solid foundation for your jack. Pre-masked areas for welding means no powder coat to grind away, for a quick and easy installation! A must for all track and lowered cars! Manufactured of 1" x 1.5" x .083" rectangular tubing for great strength-to-weight ratio.

*To achieve the ultimate in chassis stiffness, go with Stiffeners' **Fully Integrated Technology (FIT) System!** See buystiffeners.com for more details or ask your dealer!*

(Please read all instructions prior to beginning installation. Contact your dealer with any questions.)

Kit Includes:

- 2 Stiffening Rails
- 2 3/16" Pop Rivets
- 4 Plastic End Plugs

Required Tools:

- MIG Welder
- C-grips or C-clamps
- Marker or Paint-pen
- Drill & 3/16" drill bit

Install Time: Approximately 1 hr.

Installation:

1. Raise vehicle to allow access for installation. [NOTE: It is recommended the vehicle's weight be supported by the suspension during installation. This can be accomplished by using a drive-on style lift, ramps or raising the car and positioning jackstands under the suspension.]
2. Disconnect battery.
3. Locate and loosen fuel line retaining bracket along passenger side rear subframe (Fig.2); this will ease movement of lines.
4. Locate fuel lines running long rocker panel pinch weld lip below passenger side door. Using 3/16" drill bit, drill out the two pop rivets holding the line clamps in place (Ref. Fig.3 & 4).
5. Gently push lines toward center of car allowing sufficient room for installation of stiffening rail. [Note: If lines show any signs of fuel leakage, replace before welding.]
6. Just in front of passenger side rear torque box locate the emergency brake cable clamp; remove retaining screw and allow cable to hang (Ref. Fig.6)
7. Check pinch weld lip for previous jack damage, straighten if required.
8. Stiffening rails are the same for the driver and passenger side. However, there is a top and front direction for them. **Rails are marked with a RED paint dot which indicates the FRONT-TOP of the rail.**
9. Remove the tape tabs located along length of stiffening rail, exposing the bare metal areas for welding.
10. Locate rail along inside of rocker panel pinch weld lip with the end of the rail approximately 25.5" from the front seat's rear mounting hole. (Fig.1). [Note: Rail should rest against bottom of floor pan in the rear and will extend past pinch weld lip 3/8"~1/2" front to rear.]
11. Starting at the front, weld within the provided bare metal areas along seam where the pinch weld and stiffening rail meet.

12. Reposition the fuel lines against the floor pan and along the stiffening rail. Position the two line clamps flat against the floor pan. Mark their location and drill with 3/16" bit through floor pan ONLY. Do not permit bit to drill into carpet. Rivet into place. (Fig. 3 & 4)
13. Tighten retaining bracket from step #3 (Fig.2).
14. On emergency brake cable from step #6, gently spread clamp open enough to remove from cable.
15. Rotate clamp 180° from original position as shown in Fig.5; mark and drill new hole with 3/16" bit.
16. Reinstall clamp on cable as shown in Fig.6 and secure to car.
17. Repeat steps 7~11 for Driver's side.
18. Clean weldments with wire brush. Spray all bare metal areas with rust preventative paint. If color matching is desired, use Textured Matte Black paint. [Note: If *Stiffeners FIT System* was purchased, perform painting after complete system is installed.]
19. Insert supplied plastic end plugs into to keep moisture out of stiffening rail.
20. Lower vehicle and reconnect battery.

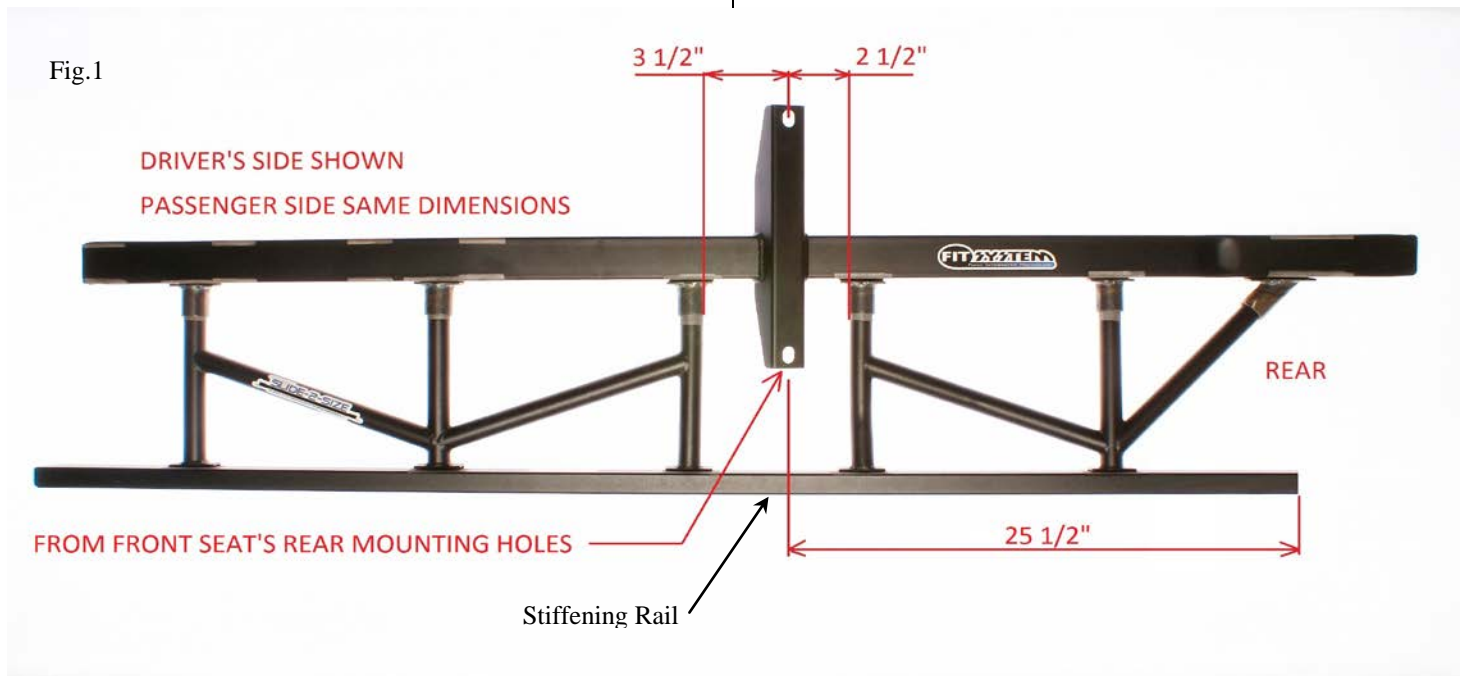

Fig.2

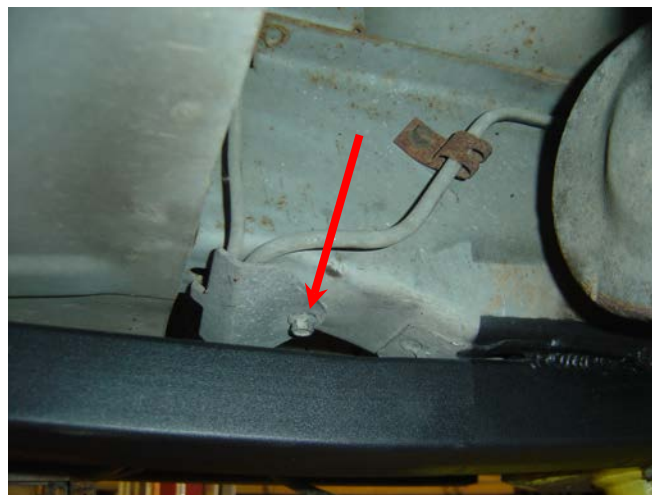

Fig.3



Fig.4



Fig.5 Original Hole

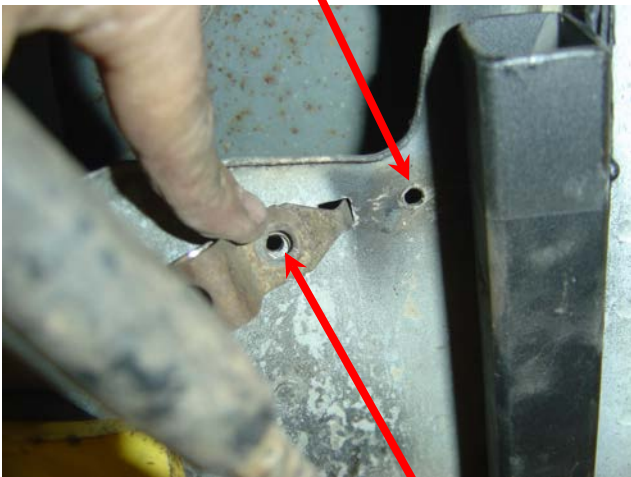

New Hole

Fig.6

