

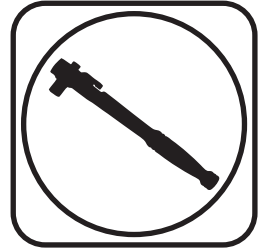

Part # 12129508 - HUB SPINDLE SN95 CALIPER BRACKET KIT



Recommended Tools



Ford Hub Spindle SN95 Caliper Bracket Kit Installation Instructions

Table of contents

- Page 2..... Included Components and Hardware
- Page 3..... Getting Started
- Page 3-5..... Caliper Bracket Installation

THIS BRACKET KIT IS DESIGNED TO FIT 1994-2004 MUSTANG BRAKES TO THE RIDETECH HUB SPINDLE.



Major ComponentsIn the box

| Item # | Part # | Description | QTY |
|--------|----------|---|-----|
| 1 | 90003537 | Caliper Bracket - Driver | 1 |
| 1 | 90003538 | Caliper Bracket - Passenger (Not Shown) | 1 |
| 2 | 90003536 | Caliper Bracket Spacer | 4 |

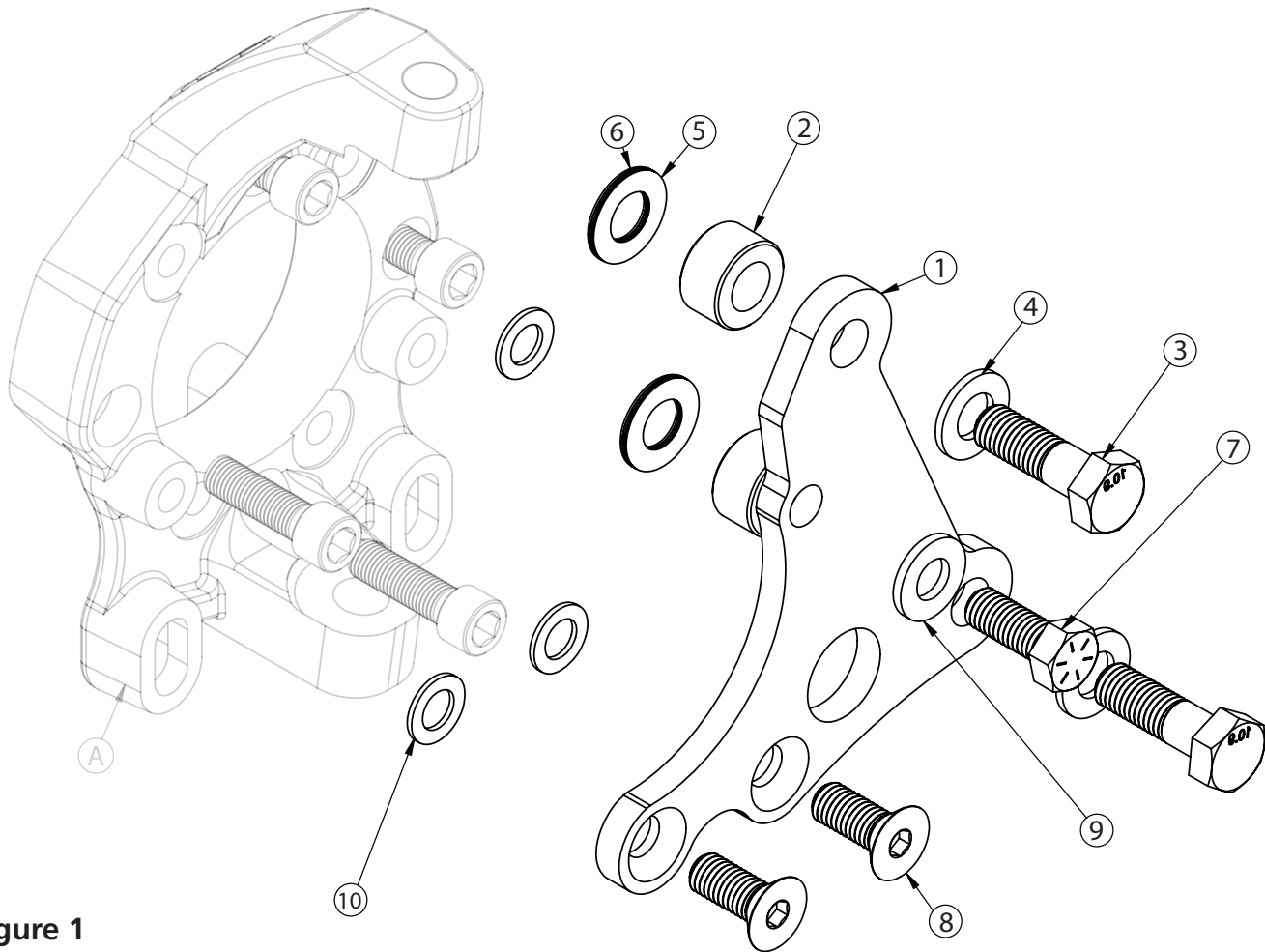

Figure 1

Hardware ListIn the box (Kit # 99010226)

| Item # | Part Number | Description | QTY | Item # | Part Number | Description | QTY |
|---------------------------|-------------|---------------------------|-----|---------------------------|-------------|---------------------------|-----|
| BRACKET TO CALIPER | | | | BRACKET TO SPINDLE | | | |
| 3 | 99121019 | M12-1.75 X 50mm Hex Bolt | 4 | 7 | 99501062 | 1/2"-13 x 1 1/4" Hex Bolt | 2 |
| 4 | 99123002 | M12 Flat Washer | 4 | 8 | 99501075 | 1/2"-13 x 1 1/4" FHSCS | 4 |
| SHIM PACK | | | | 9 | 99503014 | 1/2" SAE Flat Washer | 2 |
| 5 | 99503018 | Shim .016" thick, 1/2" ID | 8 | 10 | 99503017 | Shim .063" thick, 1/2" ID | 6 |
| 6 | 99503019 | Shim .032" thick, 1/2" ID | 8 | | | | |



Getting Started.....

These spindles are designed around OEM 1994-2004 SN95 Mustang brakes. Aftermarket brakes that are designed for these cars will also fit this spindle.

Caliper Bracket Installation

Caliper bracket and brake mounting will differ depending on the brake kit being used.

We recommend mocking up the brakes with clean dry threads before applying any loctite to the hardware.

The brake bracket kits include shims for mounting the caliper brackets and calipers. The caliper brackets will use 1/2" ID .063" thick shims. This kit includes 2 different thicknesses of shims for caliper mounting, .016" and .032" thick.

The next steps will cover the installation of caliper brackets on the Ridetech spindle. ***Again, mock up the brake kits with clean dry threads before using any loctite on the hardware.*** We are showing the installation of the caliper bracket with the spindle off the car so it can be shown clearly.



1. Lay a .062" thick, 1/2" ID shim on each of the caliper brackets (3) mounting holes.



2. The caliper brackets are side specific. They have a D & P stamped in them. Lay the correct side caliper bracket on top of the shims, aligning the mounting holes with the mounting holes of the bracket. The counter sunk holes should facing up.



Caliper Bracket Installation



3. Insert a 1/2"-13 x 1 1/4" flat head socket cap screw in each of the lower mounting holes. Install a 1/2" flat washer on a 1/2"-13 x 1 1/4" hex bolt and insert it in the upper mounting hole. Tighten the hardware to 75 ft-lbs.



4. Install the rotor on the hub. Thread some lug nuts on the threads of the hub to hold the rotor tight on the hub.



5. The kit includes spacers that will be installed between the caliper bracket and caliper mount. Install a M12 flat washer on each of (2) M12-1.75 x 50mm hex bolts. Insert the bolts through the caliper bracket, installing a spacer on each bolt. Line the caliper mount up with the hardware and thread in the bolts.



Caliper Bracket Installation



6. You can use feeler gauges to measure the distance between the caliper bracket and rotor to make sure the bracket is centered as much as possible. If the caliper mount is tighter on the back side, put shims on the caliper bracket/spindle. If the caliper bracket is tighter on the front side, put shims between the caliper bracket/caliper mount. After you are happy with the fitment, the hardware will need to red loctite and torqued. Torque the 1/2" bracket to spindle hardware to 80 ft-lbs. Torque the M12 hardware to 69 ft-lbs.

Note: If you are installing aftermarket brakes, refer to the brake kit instructions for measuring the caliper placement.



7. Install the brake pads and caliper.

8. FINISH PLUMBING THE BRAKE SYSTEM AND BLEED THE SYSTEM.