

SERVICE PROCEDURE:

1. Remove Carefully the Intake Manifold per the service procedure outlined in shop manual.
2. Clean the mounting surface.
3. Measure the step height of the coolant cap of the original manifold,
 - If the coolant outlet height is 7.5mm (0.295inch) or higher than use Spacer crossover which is included in the Intake manifold Kit Bag
 - If the measurement is less than 7.5mm (0.295inch), Spacer Crossover is not needed.

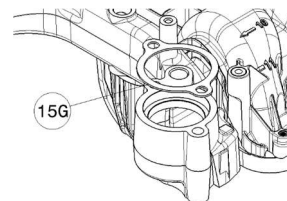

15G – SPACER CROSSOVER



4. Follow the steps mentioned in Workshop manual to Install new Intake manifold supplied (Picture shown Below)



5. Use the Existing Intake Cylinder Head Mounting bolts to install the Manifold.

6. Tighten intake bolts as follows in sequence as shown below:

Stage One: 2 Nm (18 inch lbs.)
 Stage Two: 25 Nm (18 ft. lbs.)

7. Add 15F O-RING THERMOSTAT Thermostat Seal from the Kit Bag



15F- Thermostat Seal

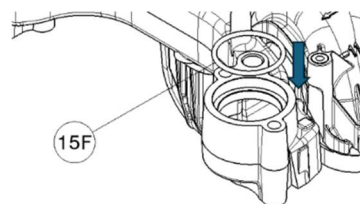

8. Install 15E Thermostat from the Kit Bag



15E – Thermostat

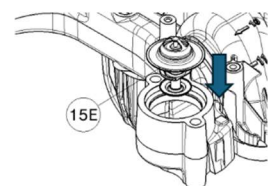

9. Assemble coils (Qty: 8) with 15K - M5 screw (SCREW M5 X 0.8) from the Kit Bag



Assembly Coil



15F - SCREW M5 X 0.8

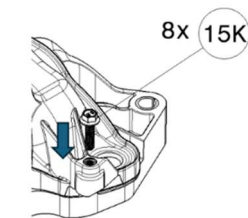

10. Assemble Fuel Rails with SCREW M6 FUEL RAIL (15L) OF QTY 4 from the Kit Bag

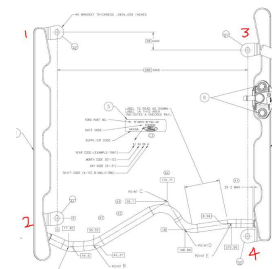

-9F792-



15L - SCREW M6 FUEL RAIL

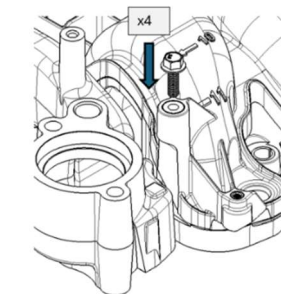

11. Add Alternator Bracket (14) and watch the Gap between Bracket and the Manifold.



14 - Bracket

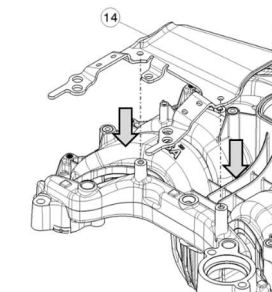

12. If the Gap exist then add the Spacer (15J) on the Manifold (Based on the seating of the alternator)



15J Spacer

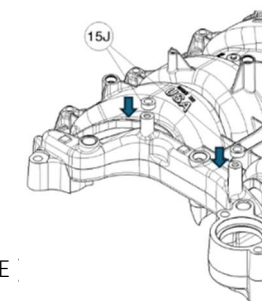

- 13A. Add the Plug (15A) into the Crossover hole with the Qty of 2 for the below Vehicle Models (9W7E)

15A PLUG



Applicable Models:

- 2005 CROWN VIC; 2005 GRAND MARQ (EN53/EN114) ;2005 LINCOLN TOWN CAR
- 2008-11 CROWN VIC / 4.6L SOHC EFI NA CIV8 G-NP; 2000-01 GRAND MARQ (EN53/EN114)
- 2000 MUSTANG (SN95) - MOD 4.6L SOHC EFI NA V8 G-HP
- 2001 LINCOLN TOWN CAR - LESS ENGINE OIL COOLER
- 2001 CROWN VIC - SPORT EQUIPMENT PACK
- 2001-04 MUSTANG (SN95)- MOD 4.6L SOHC EFI NA V8 G-HP
- 2004 MUSTANG (SN95)- ALL MOD 4.6L GAS ENGINES

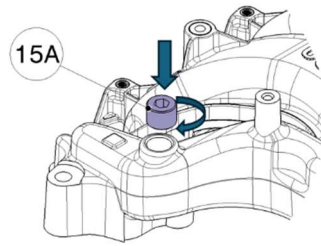

13B. Add one Plug into the Crossover hole and Install Fitting (17A) from Kit Bag on another crossover Hole for the below mentioned Models only.

(3W7E and 1W7E)

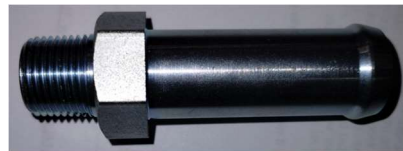

17A Fitting

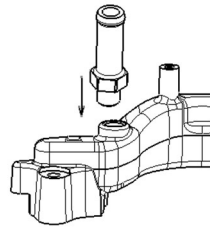

Applicable Models :

- 2009-14 ECONOLINE / R-M 4.6L SOHC EFI NA CIV8 G-NP
- 2009-10 F150/LINCOLN MARK LT / R-M 4.6L SOHC EFI NA CIV8 G-NP

14A. Add Plastic Barb (15B) which is applicable to below mentioned Vehicles (9W7E/1W7E/3W7E)



15B PLASTIC BARB

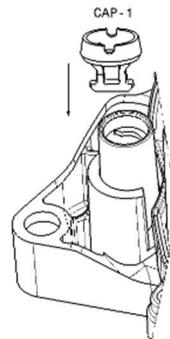

Applicable Models :

- 2005 CROWN VIC
- 2005 GRAND MARQ (EN53/EN114)
- 2005 LINCOLN TOWN CAR
- 2008-11 CROWN VIC / 4.6L SOHC EFI NA CIV8 G-NP
- 2000-01 GRAND MARQ (EN53/EN114) - SPORT EQUIPMENT PACK
- 2000 MUSTANG (SN95) - MOD 4.6L SOHC EFI NA V8 G-HP
- 2001 LINCOLN TOWN CAR - LESS ENGINE OIL COOLER
- 2001 CROWN VIC - SPORT EQUIPMENT PACK
- 2001-04 MUSTANG (SN95)- MOD 4.6L SOHC EFI NA V8 G-HP
- 2004 MUSTANG (SN95)- ALL MOD 4.6L GAS ENGINES

14B. Add Coolant Cap (15C) with O-Ring (150) for the below mentioned Vehicles (9L3E)



15C CAP and 15B O-RING

Applicable Models :

- 2005 CROWN VIC
- 2005 GRAND MARQ (EN53/EN114)
- 2005 LINCOLN TOWN CAR
- 2008-11 CROWN VIC / 4.6L SOHC EFI NA CIV8 G-NP
- 2000-01 GRAND MARQ (EN53/EN114) - SPORT EQUIPMENT PACK
- 2000 MUSTANG (SN95) - MOD 4.6L SOHC EFI NA V8 G-HP
- 2001 LINCOLN TOWN CAR - LESS ENGINE OIL COOLER
- 2001 CROWN VIC - SPORT EQUIPMENT PACK
- 2001-04 MUSTANG (SN95)- MOD 4.6L SOHC EFI NA V8 G-HP
- 2004 MUSTANG (SN95)- ALL MOD 4.6L GAS ENGINES

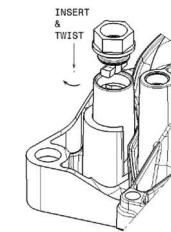

15. Add the SPACER-LG (15M) if needed when installing the alternator on the bracket



15M SPACER-LG

INSTALL INSTRUCTION ILLUSTRATION

- 2005 CROWN VIC
- 2005 GRAND MARQ (EN53/EN114)
- 2005 LINCOLN TOWN CAR
- 2008-11 CROWN VIC / 4.6L SOHC EFI NA CIV8 G-NP
- 2000-01 GRAND MARQ (EN53/EN114) - SPORT EQUIPMENT PACK
- 2000 MUSTANG (SN95) - MOD 4.6L SOHC EFI NA V8 G-HP
- 2001 LINCOLN TOWN CAR - LESS ENGINE OIL COOLER
- 2001 CROWN VIC - SPORT EQUIPMENT PACK
- 2001-04 MUSTANG (SN95) - MOD 4.6L SOHC EFI NA V8 G-HP
- 2004 MUSTANG (SN95) - ALL MOD 4.6L GAS ENGINES

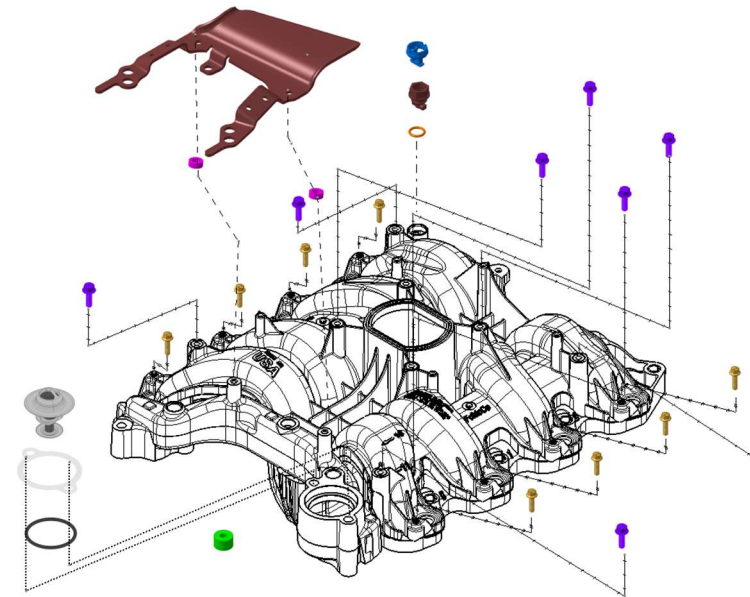

116. Add Throttle body adapter if replacing as shown with three M6 screws (17B) and one self tap screw (17C).

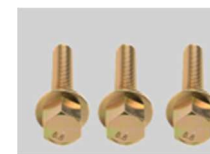

17B M6 SCREW



17C SELF TAP SCREW

