



INSTALLATION INSTRUCTIONS



2018 FORD MUSTANG GT 5.0L | PART NO. 19418

BILL OF MATERIALS:

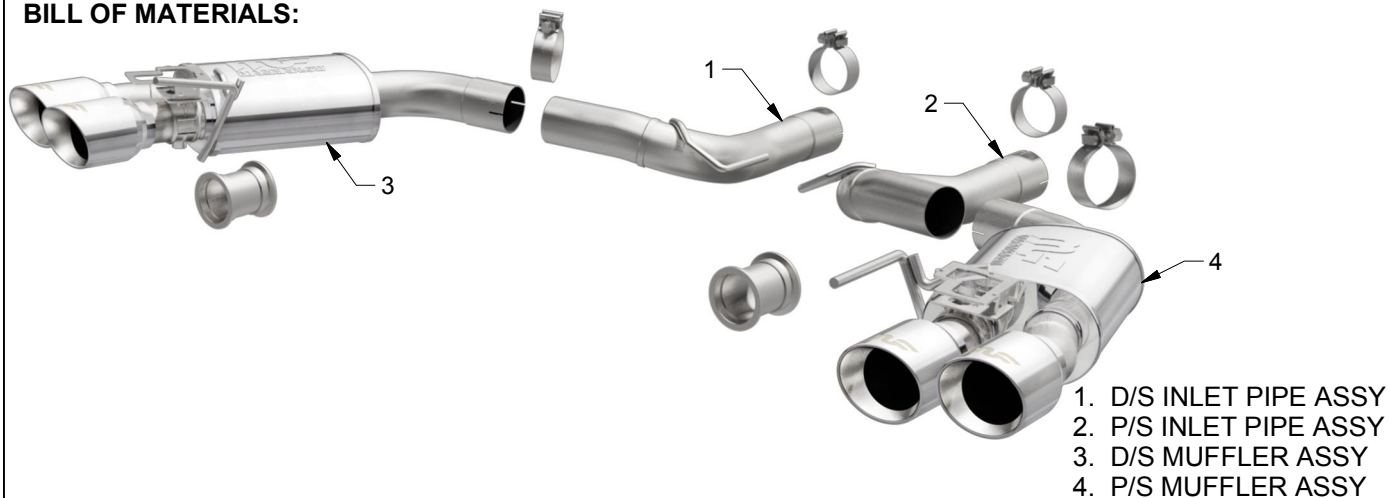

WEAR SAFETY GLASSES



READ INSTRUCTIONS THOROUGHLY BEFORE INSTALLING PRODUCT

SHOP SUPPLIES:



SPRAY LUBRICANT

To ease removal of existing exhaust components (especially on older vehicles) spray penetrating lubricant on all fasteners and hangers/insulators that will be loosened or removed and let soak before disassembly.

HARDWARE KIT:

- 1. [2] 3.00" Clamp
- 2. [2] 2.50" Clamp
- 3. [2] 2.50 Valve delete

MINIMUM REQUIRED TOOLS:



15mm
13mm



Hanger Tool
(Or Pry Bar)



Sawzall or similar cutting tool

MAGNAFLOW RECOMMENDS PROFESSIONAL INSTALLATION ON ALL THEIR PRODUCTS



WARNING: When working on, under, or around any vehicle exercise caution. Please allow the vehicle's exhaust system to cool before removal, as exhaust system temperatures may cause severe burns. If working without a lift always consult vehicle manual for correct lifting specifications. Always wear safety glasses and ensure a safe work area. Serious injury or death could occur if safety measures are not followed.

ATTENTION: Always install any supplied band or U-bolt clamps to the proper torque specifications of 40-45 ft-lbs for band clamps and 30-35 ft-lbs for U-bolt clamps. Over tightening will result in the clamp breaking and will NOT be warranted by MagnaFlow.

INSTALLATION INSTRUCTIONS

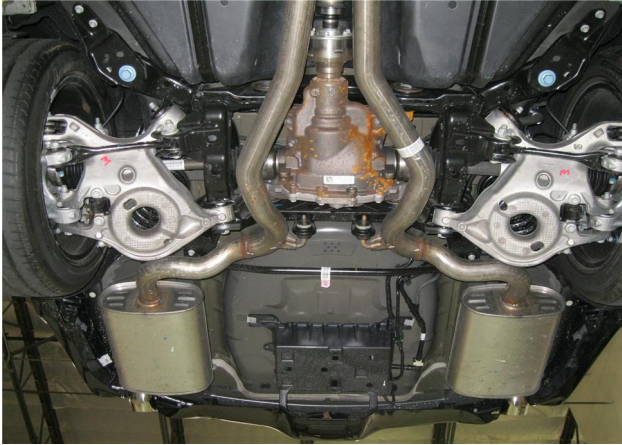

Step 1. Begin removing the OEM exhaust system by cutting both pipes exiting the resonator. Measure and cut on the driver side 5" from the tip of the hanger. Cut the passenger side also from the tip of the hanger 5.5" back. Next, extract the hangers from the rubber insulators and remove the OEM mufflers. Retain insulators as they will be used to install the new system.

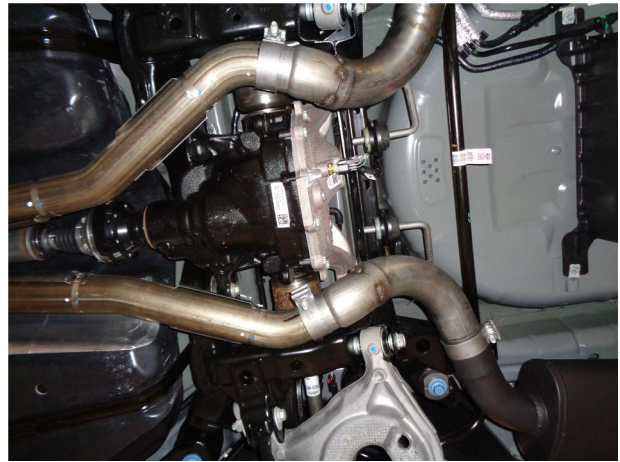

Step 2. Begin installation of the new system by attaching both Inlet Pipe Assemblies to the pipes you have just cut. Loosely secure using the supplied 2.50" clamps. Engage the welded hangers to the rubber insulators. Leave all clamps loose until final adjustment.

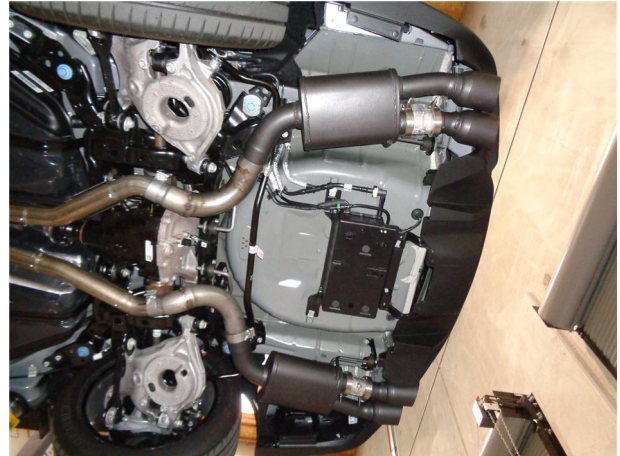

Step 3. Next attach both Muffler Assemblies to the Inlet Pipe Assemblies using the supplied 3.00" clamps and fitting the hangers into the rubber insulators.

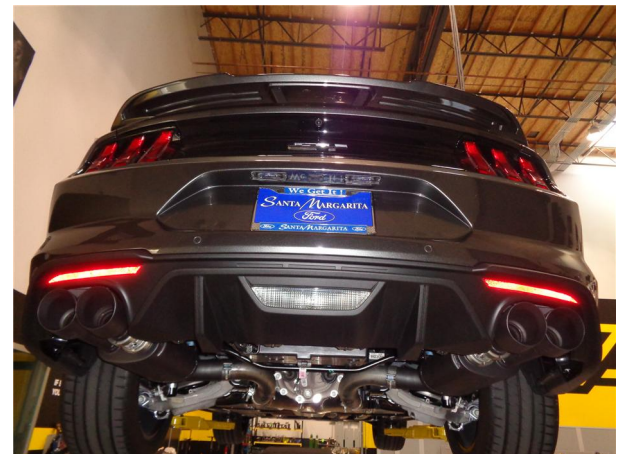

Step 4. Once a final position has been chosen for the new exhaust system, evenly tighten all clamps from front to rear using the torque specifications on page one of the instructions. Inspect all fasteners after 25-50 miles of operation and re-tighten if necessary.