

2015+ Mustang Hood Struts

Part No. 80U900, 80U901



STOP – Verify that all of the following components are included in kit before beginning installation:

- #1 (1) Driver Side (LH) Body Bracket with ball mount
- #2 (1) Passenger Side (RH) Body Bracket with ball mount
- #3 (1) Driver Side (LH) Hood Bracket with ball mount
- #4 (1) Passenger Side (RH) Hood Bracket with ball mount
- #5 (2) Gas Struts (Hood Struts)

Tools Needed:

- Flat Screwdriver
- 10 mm Socket
- 13mm Socket
- Ratchet



****If you have questions or concerns, CONTACT MRT BEFORE INSTALLING or MODIFYING the product. Failure to do so will void warranty and make ineligible for return or exchange.****

Installation of Hood Struts:



Figure 1



Figure 2

- 1.) Locate the hood mounting hinge on the driver side of the hood. (fig 1)
- 2.) Loosen the upper mounting nut (closest to the front of the car) about 3/4 of the way. (fig 2)

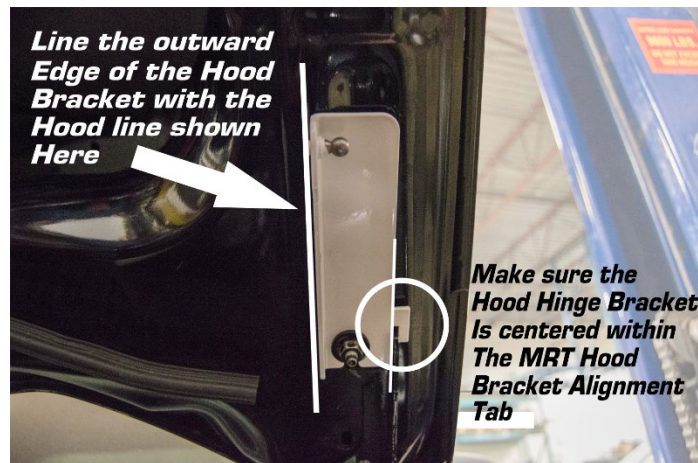

Figure 3

- 3.) Position the LH MRT mounting bracket so the outer ridge of the OE hinge bracket is centered within the alignment tab. Slide the LH MRT mounting bracket under the loosened 13mm nut. Once you ensure the bracket is fully pressed in place, tighten the 13mm nut. (fig 3)

** be sure that the LH stamp on the bracket is facing the hood*

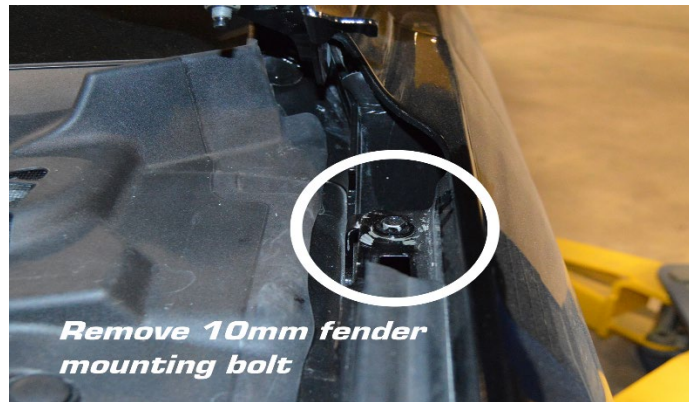

Figure 4

- 4.) On the Driver side fender, remove the rear (closest to the back of the engine bay) 10mm mounting bolt. **(fig 4)**

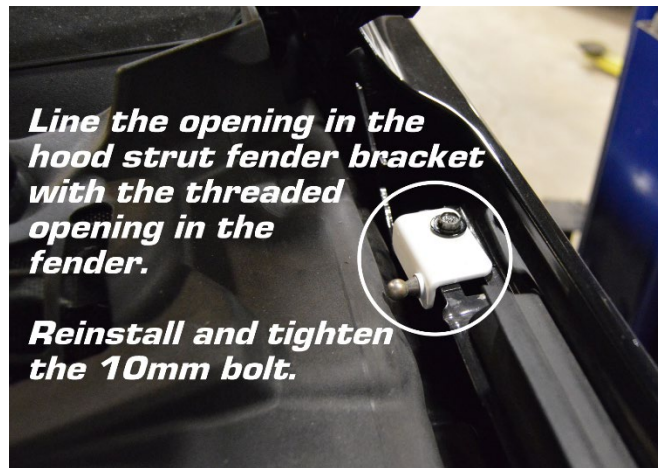

Figure 5

- 5.) Install the LH MRT side fender mounting bracket by lining the bolt hole with the mounting hole in the bracket, and slide the mounting bolt back in place and tighten it down. **(fig 5)**
** be sure that the LH stamp on the bracket is facing the fender*
- 6.) Repeat process on the passenger side.
- 7.) Once all four brackets are in place, remove the hood from the prop rod so it's able to move up and down freely.
- 8.) Work your way to the driver side of the hood to install the gas cylinder. You will want the larger portion of the cylinder facing upward, and make sure you can read the MRT clearly (the M will be on the top for the driver side, the flag will be on the top for the passenger side).

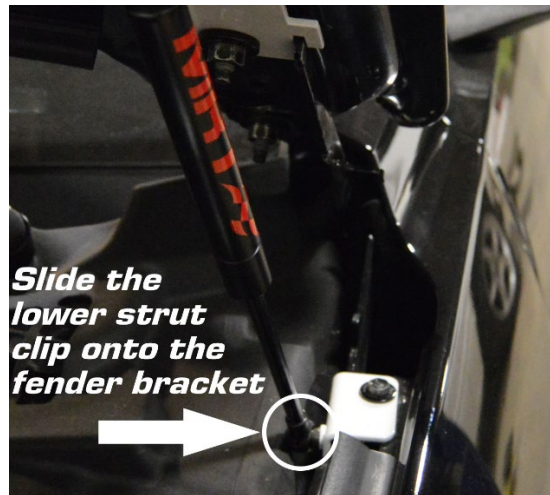

Figure 6

- 9.) Snap the lower side of the cylinder onto the fender first by lining the ball stud on the bracket to the socket of the cylinder, and press it into place. (fig 6)



Figure 7

- 10.) You may need to rotate the upper portion of the cylinder 180 degrees before the upper portion will properly align with the hood mounting bracket. Once it's lined up, press the upper socket of the cylinder onto the ball stud of the hood mounting bracket. (fig 7)
- 11.) Repeat for the passenger side.
- 12.) Once complete, close the hood and check the hood to fender alignment on both sides, then you're good to go.

Congratulations, you now have the highest quality, best valued hood strut in the market installed on your Mustang!

Please feel free to contact us at any point with questions or concerns

at 734-455-5807 or via email at Sales@MRT-Direct.com