

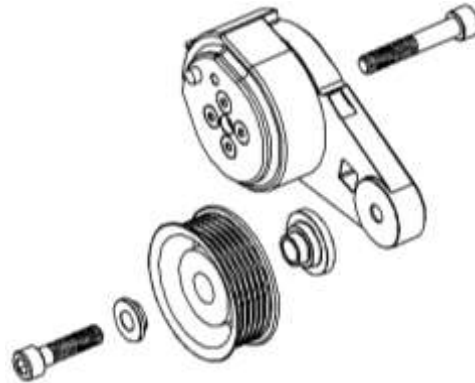

## **SUPERCHARGER INSTALLATION MANUAL SUPPLEMENT**

### **2011-2017 FORD 5.0L-5.2L MUSTANG ENGINES**

1. Using a 1/2" breaker bar, release tension from tensioner and remove belt.
2. Remove the spring-loaded tensioner by removing the 10mm SHCS securing tensioner to idler plate.
3. Remove the idler pulley from the tensioner by removing the 10mm SHCS.
4. Using the supplied hardware, assemble idler pulley to billet tensioner. Use the supplied step spacer as shown, between idler and tensioner arm. Use the supplied step washer to center the bearing and the 10mm x 40mm SHCS (10-Rib uses 10mm x 60mm SHCS) bolt to secure idler to tensioner. Torque to 18 lbs-ft.



5. Install spring loaded tensioner to idler plate using the supplied 10mm x 60mm SHCS. Torque to 25 lbs-ft.
6. Reinstall belt as previously routed.

