



Part Number: M-7210-M8A
Part Description: GT350 Short Throw Shifter
INSTALLATION INSTRUCTIONS

NO PART OF THIS DOCUMENT MAY BE REPRODUCED WITHOUT PRIOR AGREEMENT AND WRITTEN PERMISSION OF FORD PERFORMANCE PARTS.

Please visit www.performanceparts.ford.com for the most current instruction information

!!! PLEASE READ ALL OF THE FOLLOWING INSTRUCTIONS CAREFULLY PRIOR TO INSTALLATION.

AT ANY TIME YOU DO NOT UNDERSTAND THE INSTRUCTIONS, PLEASE CALL THE FORD PERFORMANCE TECHLINE AT 1-800-367-3788 !!!



SHIFTER KIT:

Quantity	Part Name
1	Short Throw Lever
1	Reverse Lockout Collar
1	Jam Nut
1	Roll Pin
1	BLUE Thread Locking Compound
1	Grease

NOTE: THIS KIT MAY ALSO BE USED WITH FORD PERFORMANCE SHIFT KNOB (M-7213-MSVT) WHICH IS SOLD SEPERATLY

Factory Ford shop manuals are available from Helm Publications, 1-800-782-4356

NO PART OF THIS DOCUMENT MAY BE REPRODUCED WITHOUT PRIOR AGREEMENT AND WRITTEN PERMISSION OF FORD PERFORMANCE PARTS.

INSTALLATION INSTRUCTIONS:

STEP 1: Raise and support vehicle to gain access to underside.

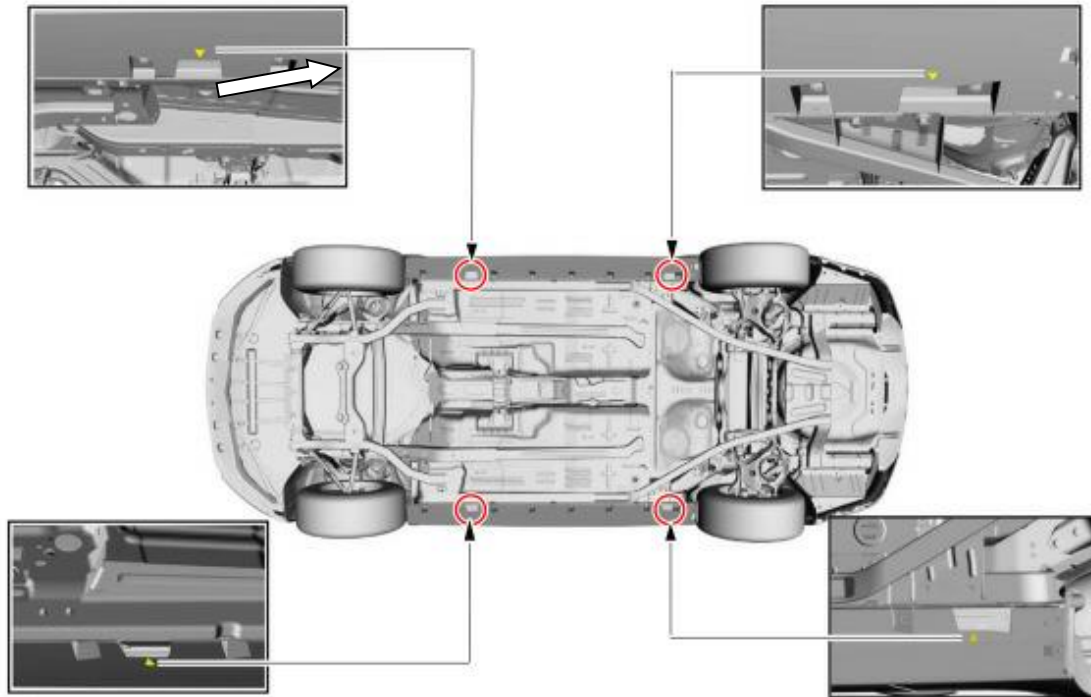

WARNING: Identify the correct jacking points by locating the triangle stamped into the unibody sheet metal or vehicle frame. Raising a vehicle in any other location may result in vehicle shifting or falling. Failure to follow this instruction may result in serious personal injury.

WARNING: Never get underneath a vehicle that is supported only by a jack. The jack could unintentionally lower. Always support vehicle with floor stands. Failure to follow these instructions may result in serious personal injury.

NOTICE: The jack provided with the vehicle is intended to be used in an emergency for changing a deflated tire. To avoid damage to the vehicle, never use the jack to hoist the vehicle for any other purpose.

Part Number: M-7210-M8A
Part Description: GT350 Short Throw Shifter
INSTALLATION INSTRUCTIONS

NO PART OF THIS DOCUMENT MAY BE REPRODUCED WITHOUT PRIOR AGREEMENT AND WRITTEN PERMISSION OF FORD PERFORMANCE PARTS.

NOTICE: Do not attempt to use jack pressure on either the front bumper or the rear bumper on any vehicle. Damage to bumper covers will occur.

NOTICE: Damage to the suspension, exhaust or steering linkage components may occur if care is not exercised when positioning the hoist adapters prior to lifting the vehicle.

NOTICE: To prevent possible damage to the underbody, do not drive the vehicle onto the drive-on lift without first checking for possible interference.

NOTICE: When raising a vehicle on a two-column hoist, use care when positioning the vehicle so that the hoisting forks do not interfere with suspension components, mounting brackets or stabilizer mounting brackets, if equipped. In addition, use care in hoist positioning to avoid possible damage to the axle or rear cover.

STEP 2: Rotate the gearshift knob counterclockwise and remove the gearshift knob.

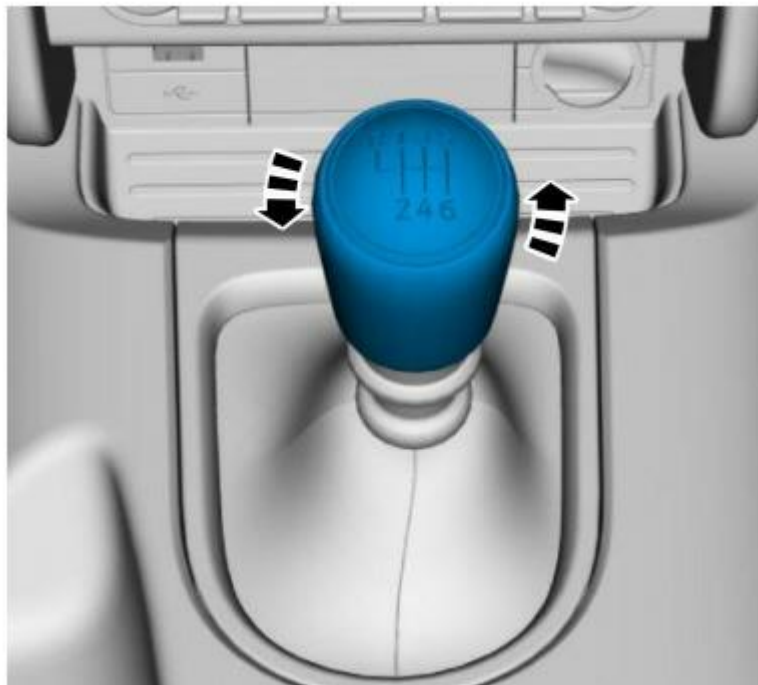

NO PART OF THIS DOCUMENT MAY BE REPRODUCED WITHOUT PRIOR AGREEMENT AND WRITTEN PERMISSION OF FORD PERFORMANCE PARTS.

STEP 3: Using an interior trim remover, release the gearshift lever boot from the floor console starting at the front sides and moving rearward.

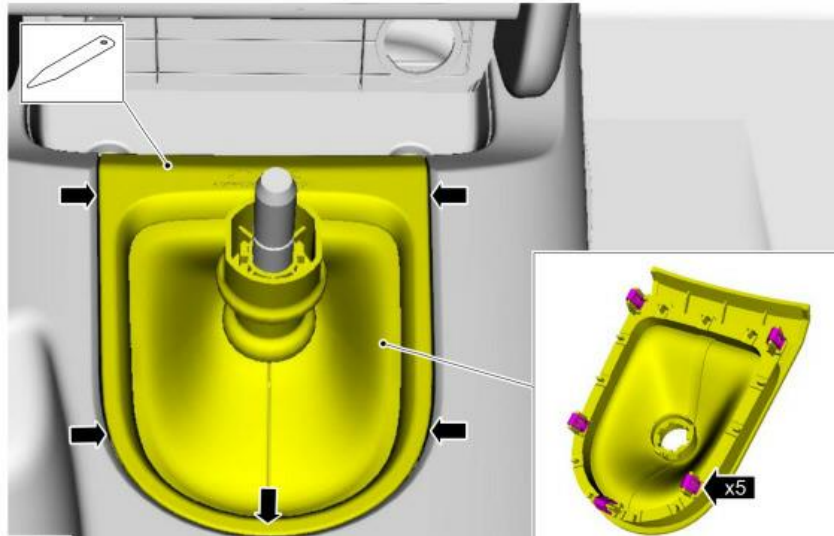

STEP 4: Release the retainers and remove the gearshift lever boot.

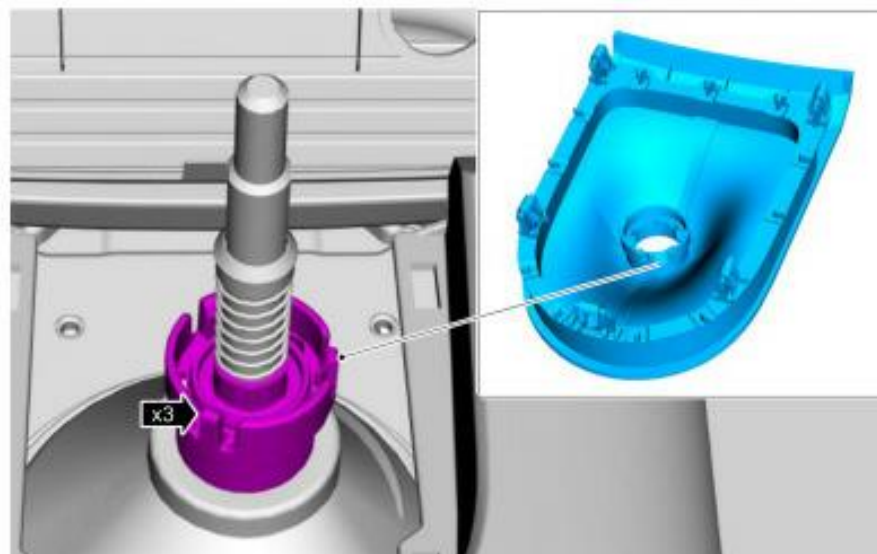

NO PART OF THIS DOCUMENT MAY BE REPRODUCED WITHOUT PRIOR AGREEMENT AND WRITTEN PERMISSION OF FORD PERFORMANCE PARTS.

STEP 5: Using a punch, remove the roll pin. Then remove the anti-rattle washer and the spring.

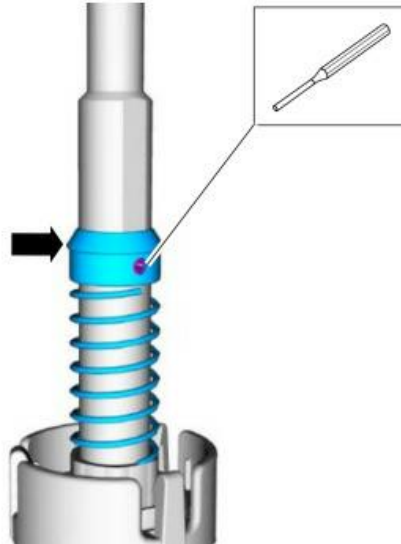

STEP 6: Remove the reverse lockout collar.

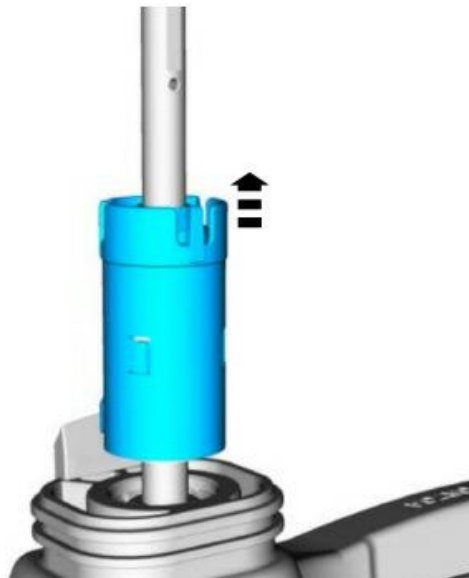

NO PART OF THIS DOCUMENT MAY BE REPRODUCED WITHOUT PRIOR AGREEMENT AND WRITTEN PERMISSION OF FORD PERFORMANCE PARTS.

STEP 7: Remove the rubber reverse lockout spacer and (2) O-Rings on the shifter shaft.

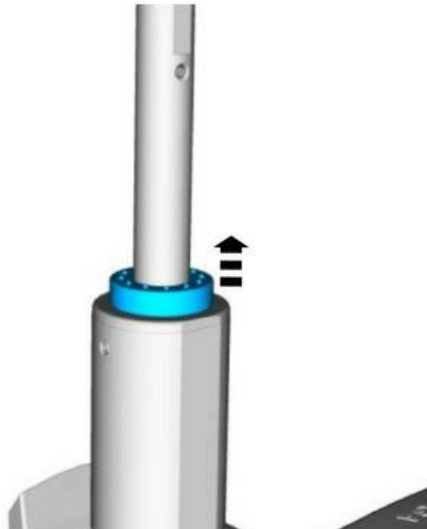

STEP 8: From the underside of the vehicle, remove the retainer clip (1). Then remove the steel pin (2). Lower the shifter actuation arm (3) from the shift lever and place to the side.

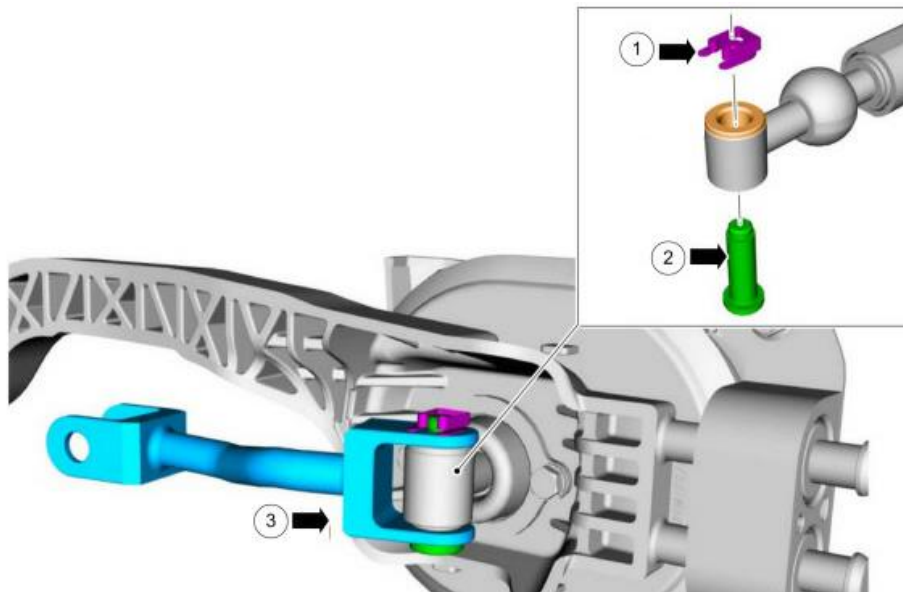



FORD PERFORMANCE

Part Number: M-7210-M8A
Part Description: GT350 Short Throw Shifter
INSTALLATION INSTRUCTIONS

NO PART OF THIS DOCUMENT MAY BE REPRODUCED WITHOUT PRIOR AGREEMENT AND WRITTEN PERMISSION OF FORD PERFORMANCE PARTS.

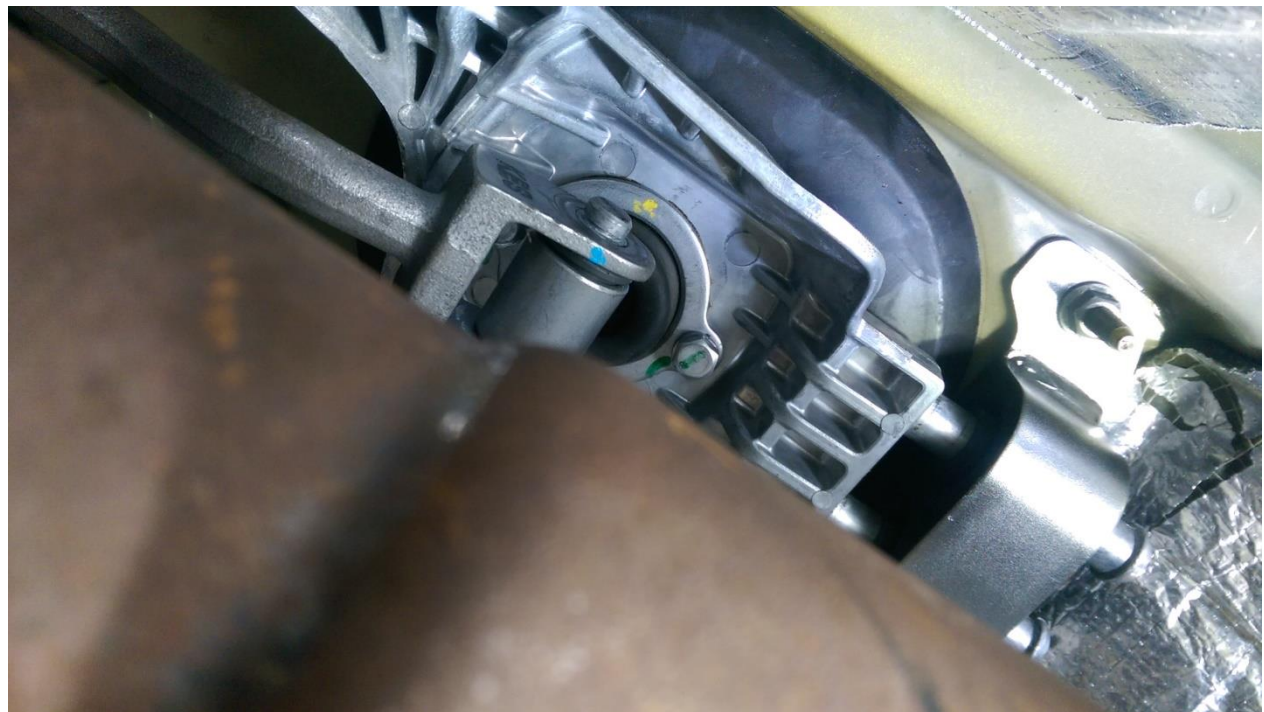
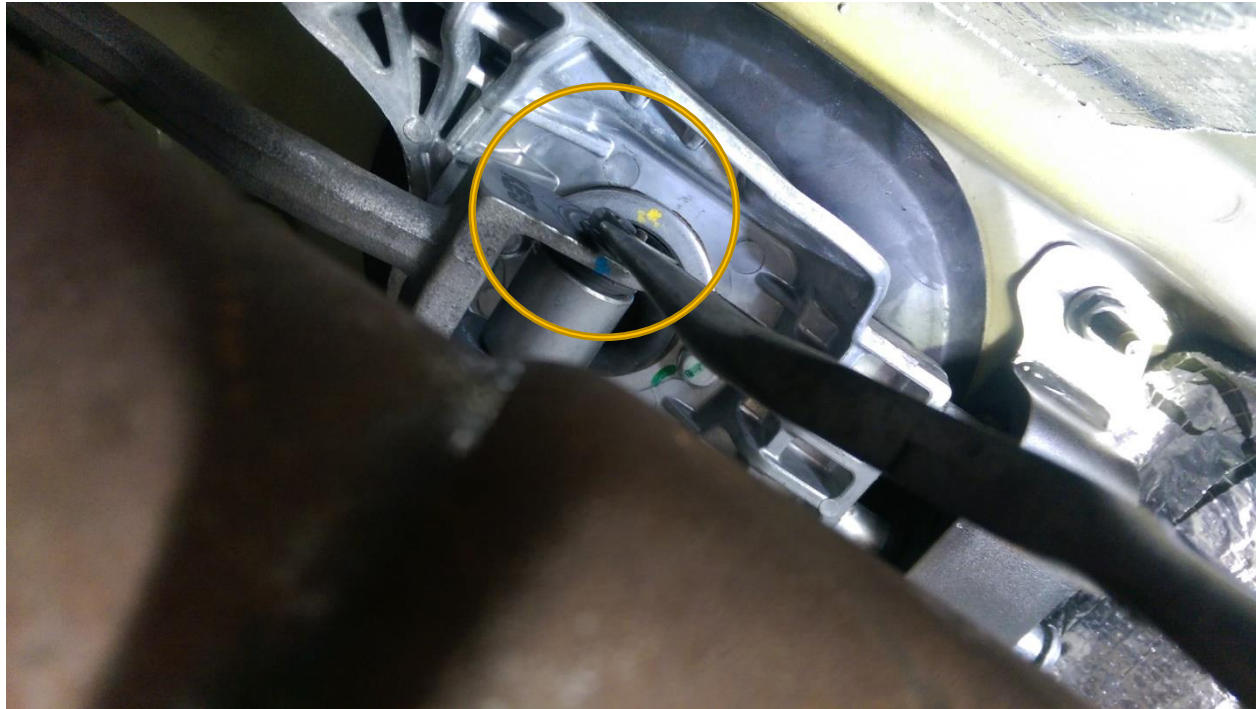

Factory Ford shop manuals are available from Helm Publications, 1-800-782-4356

NO PART OF THIS DOCUMENT MAY BE REPRODUCED WITHOUT PRIOR AGREEMENT AND WRITTEN PERMISSION OF FORD PERFORMANCE PARTS.



Factory Ford shop manuals are available from Helm Publications, 1-800-782-4356



FORD PERFORMANCE

Part Number: M-7210-M8A
Part Description: GT350 Short Throw Shifter
INSTALLATION INSTRUCTIONS

NO PART OF THIS DOCUMENT MAY BE REPRODUCED WITHOUT PRIOR AGREEMENT AND WRITTEN PERMISSION OF FORD PERFORMANCE PARTS.

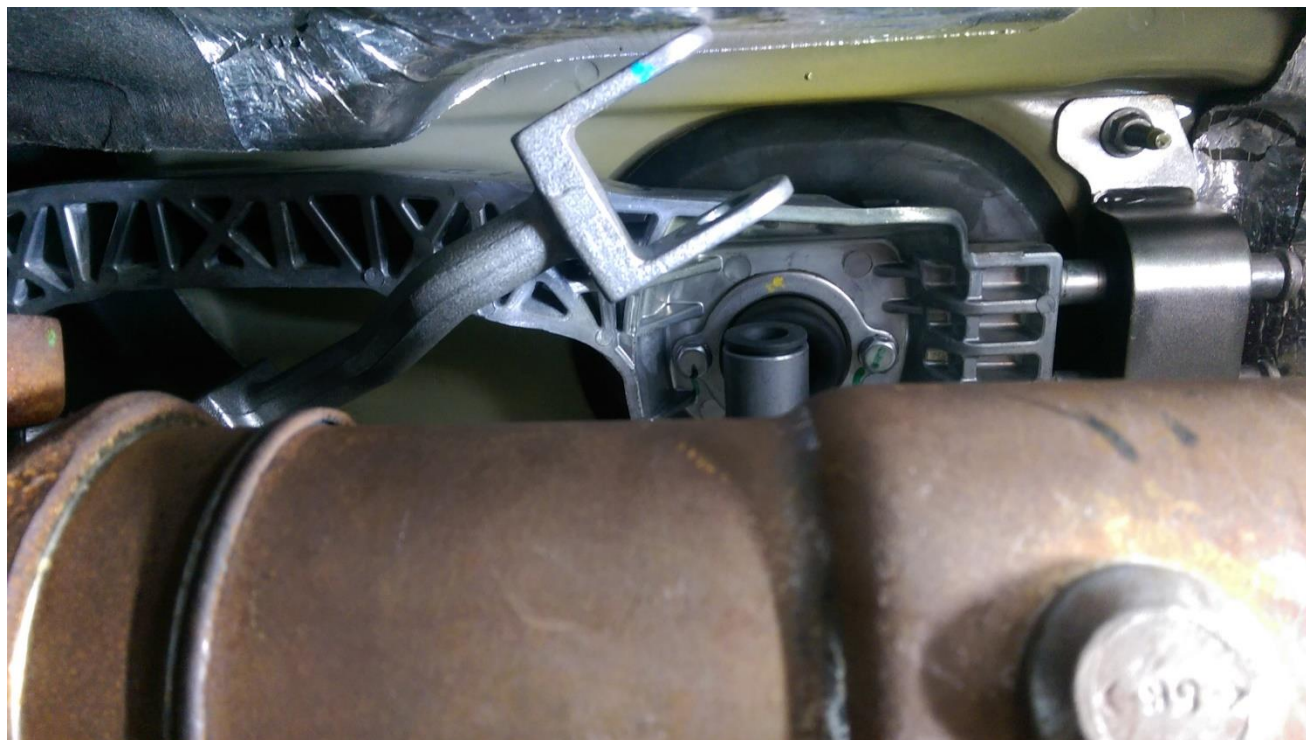

Factory Ford shop manuals are available from Helm Publications, 1-800-782-4356

NO PART OF THIS DOCUMENT MAY BE REPRODUCED WITHOUT PRIOR AGREEMENT AND WRITTEN PERMISSION OF FORD PERFORMANCE PARTS.

STEP 9: Remove (2) 10mm shifter retaining plate bolts, remove shifter retainer plate.

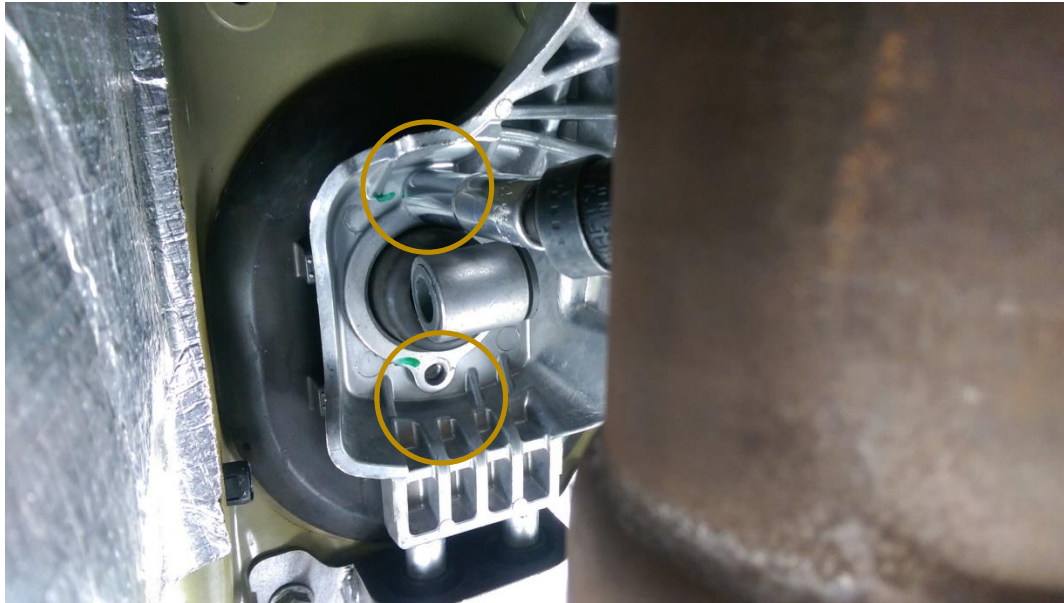

Factory Ford shop manuals are available from Helm Publications, 1-800-782-4356

NO PART OF THIS DOCUMENT MAY BE REPRODUCED WITHOUT PRIOR AGREEMENT AND WRITTEN PERMISSION OF FORD PERFORMANCE PARTS.

STEP 10: Slide the shift handle assembly downwards and out of the shifter housing. Verify that the upper shifter bushing rubber isolator comes out with the shifter handle assembly.



NO PART OF THIS DOCUMENT MAY BE REPRODUCED WITHOUT PRIOR AGREEMENT AND WRITTEN PERMISSION OF FORD PERFORMANCE PARTS.

STEP 11: Remove the upper shifter bushing rubber isolator, then remove (2) shifter ball pivot O-Rings.



STEP 12: Utilizing the steel pin removed in Step 8 or a suitable punch, gently tap the shifter pivot bushing to remove from the shifter handle assembly.



Part Number: M-7210-M8A
Part Description: GT350 Short Throw Shifter
INSTALLATION INSTRUCTIONS

NO PART OF THIS DOCUMENT MAY BE REPRODUCED WITHOUT PRIOR AGREEMENT AND WRITTEN PERMISSION OF FORD PERFORMANCE PARTS.



NO PART OF THIS DOCUMENT MAY BE REPRODUCED WITHOUT PRIOR AGREEMENT AND WRITTEN PERMISSION OF FORD PERFORMANCE PARTS.

STEP 13: Gently pull the lower shifter boot over the lower portion of the shifter to remove.



STEP 14: Remove the shift handle pivot bushing by gently pushing downwards until it is released from the pivot ball. Slide the bushing over the lower pivot to remove completely.

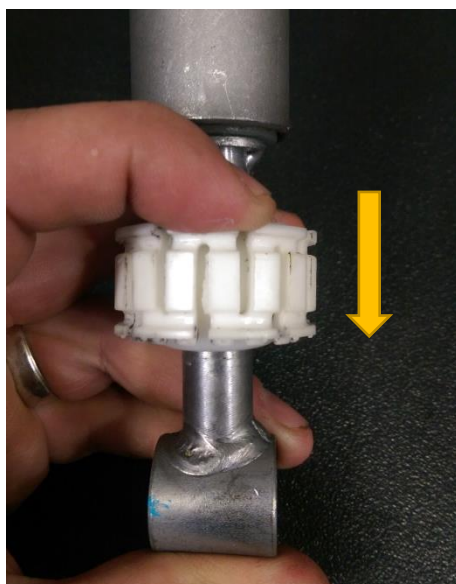

Factory Ford shop manuals are available from Helm Publications, 1-800-782-4356

NO PART OF THIS DOCUMENT MAY BE REPRODUCED WITHOUT PRIOR AGREEMENT AND WRITTEN PERMISSION OF FORD PERFORMANCE PARTS.

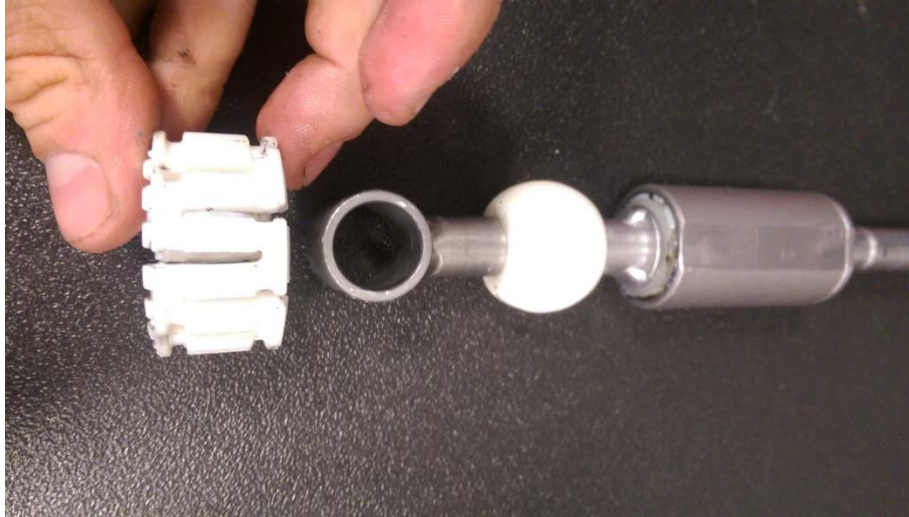

STEP 15: Install the shift handle pivot bushing onto the new shifter shaft by sliding it over the lower portion of the shifter shaft and gently pushing upwards until it is positioned over the pivot ball.



NO PART OF THIS DOCUMENT MAY BE REPRODUCED WITHOUT PRIOR AGREEMENT AND WRITTEN PERMISSION OF FORD PERFORMANCE PARTS.

STEP 16: Install the lower shifter boot by gently feeding it around the new shifter shaft.



STEP 17: Align the shifter pivot bushing with the shifter handle, using a rubber mallet gently tap the bushing into the shifter shaft until fully seated.



Factory Ford shop manuals are available from Helm Publications, 1-800-782-4356

NO PART OF THIS DOCUMENT MAY BE REPRODUCED WITHOUT PRIOR AGREEMENT AND WRITTEN PERMISSION OF FORD PERFORMANCE PARTS.

STEP 18: Install the (2) shifter ball pivot O-Rings.



STEP 19: Apply a liberal amount of the supplied grease to the shifter shaft pivot and into all the voids on the shifter pivot bushing. Articulate the bushing around to ensure grease has completely covered the shifter shaft pivot.

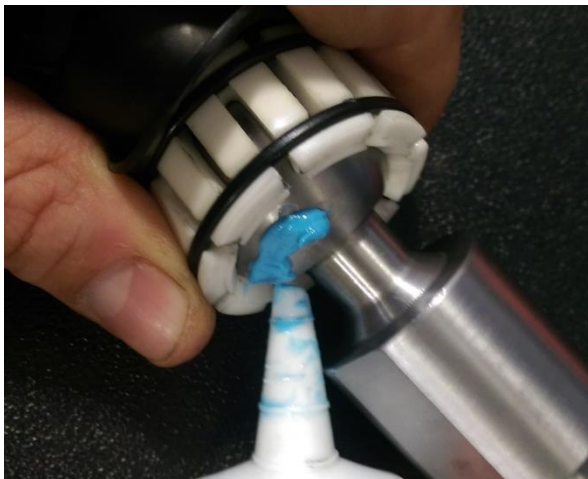

NO PART OF THIS DOCUMENT MAY BE REPRODUCED WITHOUT PRIOR AGREEMENT AND WRITTEN PERMISSION OF FORD PERFORMANCE PARTS.

STEP 20: Apply the supplied grease to the upper shifter bushing rubber isolator removed in Step 11. Reinstall onto the top of the shifter shaft pivot assembly.

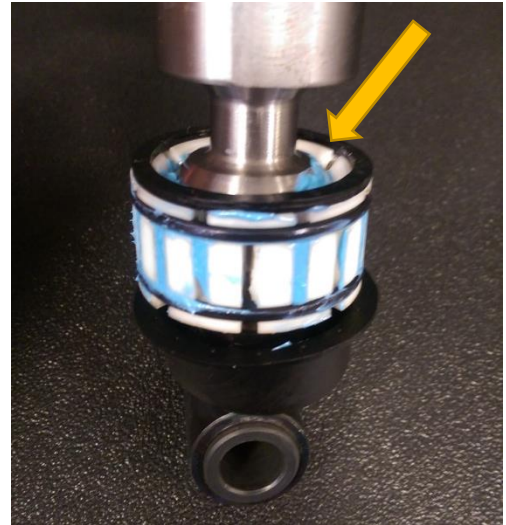

STEP 21: Slide the new shift handle assembly into the shifter housing. Verify that the upper shifter bushing rubber isolator stays in position as the assembly is installed.



NO PART OF THIS DOCUMENT MAY BE REPRODUCED WITHOUT PRIOR AGREEMENT AND WRITTEN PERMISSION OF FORD PERFORMANCE PARTS.

STEP 22: Install the shifter retaining plate. Apply the supplied Blue thread locking compound to the (2) bolts. Torque: 75 lb.in (8.5 Nm)



STEP 23: Realign the lower shifter actuation arm (3) to the new shift handle assembly. Install the steel pin (2). Install the retainer clip (1).

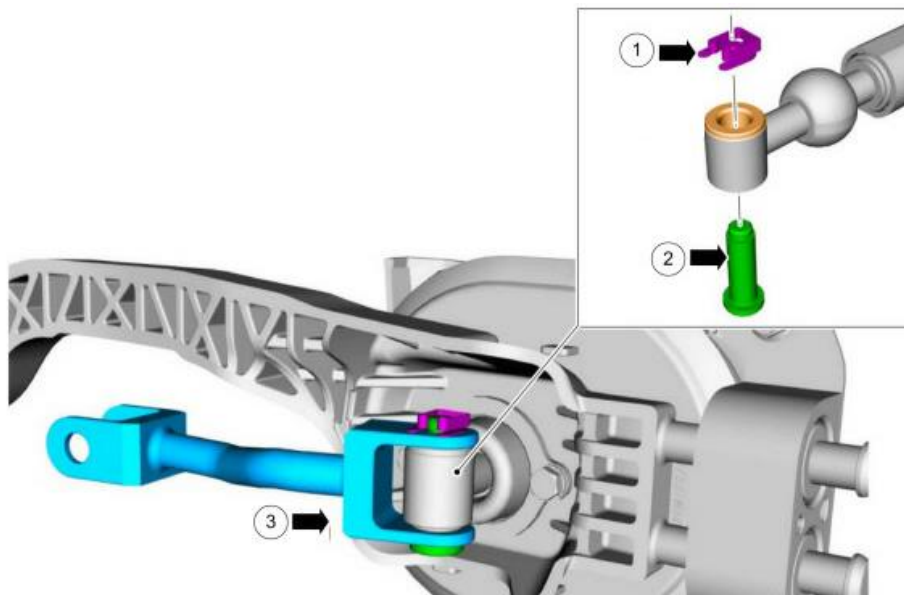



FORD PERFORMANCE

Part Number: M-7210-M8A
Part Description: GT350 Short Throw Shifter
INSTALLATION INSTRUCTIONS

NO PART OF THIS DOCUMENT MAY BE REPRODUCED WITHOUT PRIOR AGREEMENT AND WRITTEN PERMISSION OF FORD PERFORMANCE PARTS.

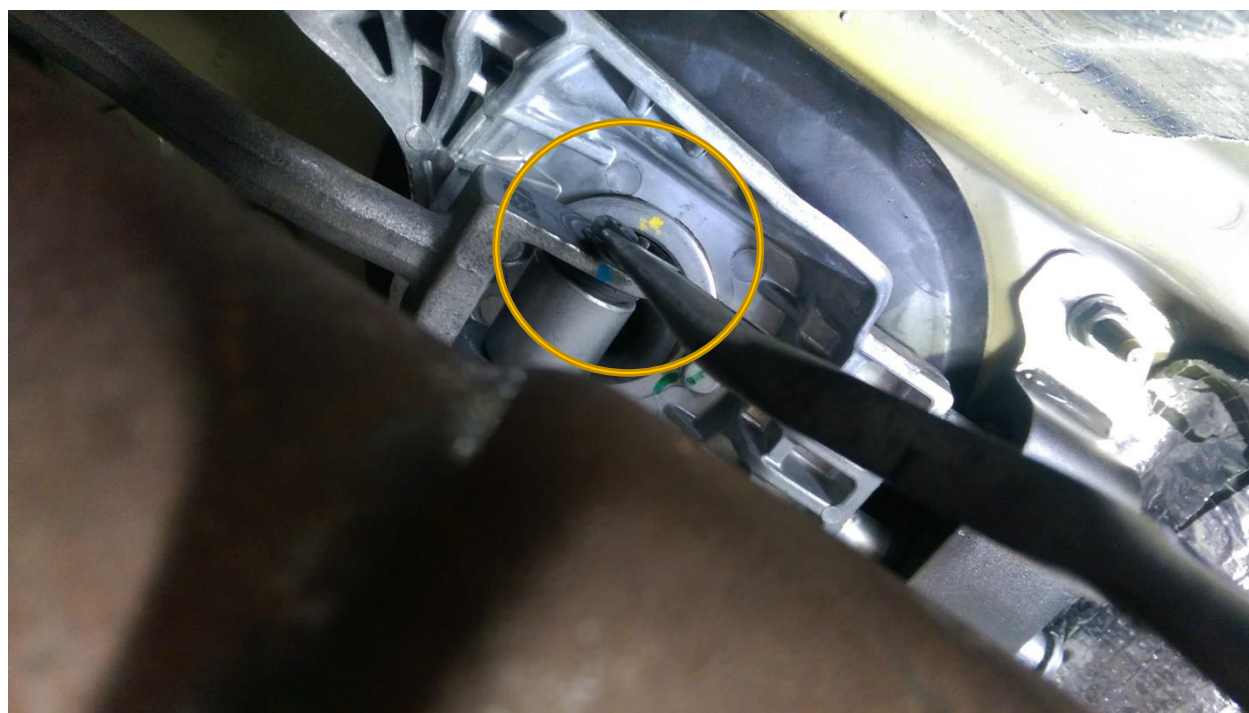

Factory Ford shop manuals are available from Helm Publications, 1-800-782-4356

NO PART OF THIS DOCUMENT MAY BE REPRODUCED WITHOUT PRIOR AGREEMENT AND WRITTEN PERMISSION OF FORD PERFORMANCE PARTS.

STEP 24: From the inside of the car, apply a liberal amount of the supplied grease to the shift handle cylinder. Then install the rubber reverse lockout spacer removed in Step 7.



STEP 25: Using a small pair of pliers, carefully remove the (2) round anti-rattle pads from the OEM reverse lockout collar. Install both anti-rattle pads into the new reverse lockout collar.

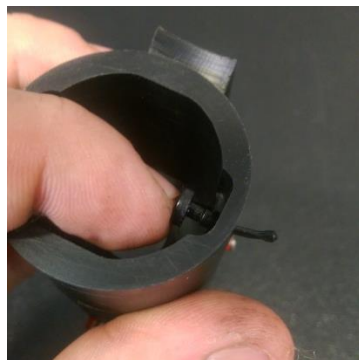
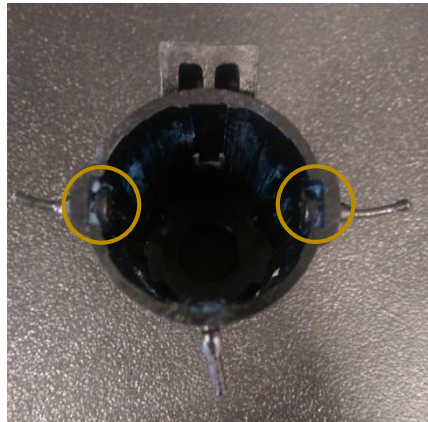

NO PART OF THIS DOCUMENT MAY BE REPRODUCED WITHOUT PRIOR AGREEMENT AND WRITTEN PERMISSION OF FORD PERFORMANCE PARTS.

STEP 26: Apply a liberal amount of the supplied grease to the inside of the new reverse lockout.

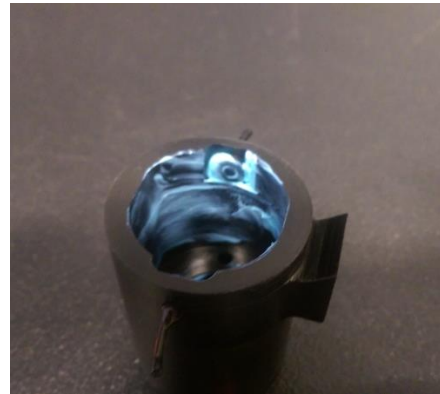

STEP 27: Install the lower O-Ring removed in Step 7, then slide the new reverse lockout collar onto the shifter shaft.

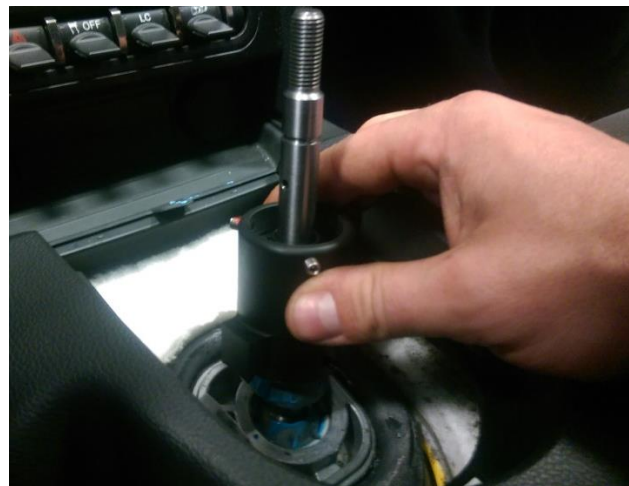

NO PART OF THIS DOCUMENT MAY BE REPRODUCED WITHOUT PRIOR AGREEMENT AND WRITTEN PERMISSION OF FORD PERFORMANCE PARTS.

STEP 28: Install the spring over the shifter shaft. Install upper O-Ring. Then install the anti-rattle washer removed in Step 5.



STEP 29: Using a suitable punch, tap the provided roll pin through the anti-rattle washer until it is centered within the shifter handle.

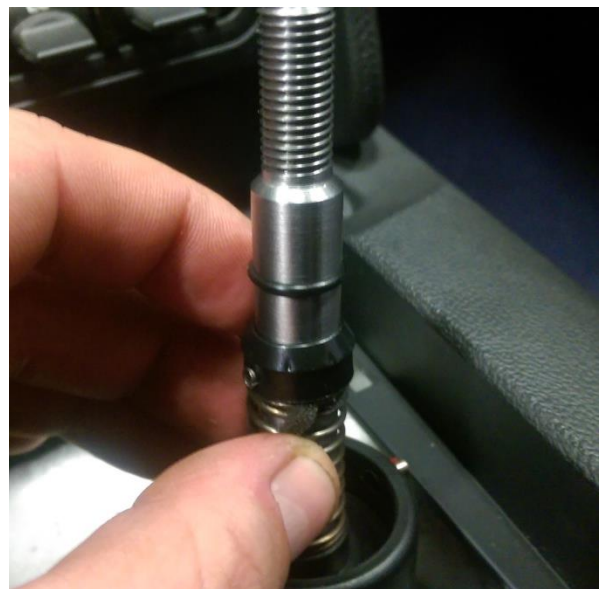

NO PART OF THIS DOCUMENT MAY BE REPRODUCED WITHOUT PRIOR AGREEMENT AND WRITTEN PERMISSION OF FORD PERFORMANCE PARTS.

STEP 30: Modify the OEM foam insulator by trimming approximately 19mm from the top edge to provide clearance for the new reverse lockout collar.



STEP 31: Install the OEM foam insulator over the shifter assembly and verify there is no interference with the reverse lockout collar.



NO PART OF THIS DOCUMENT MAY BE REPRODUCED WITHOUT PRIOR AGREEMENT AND WRITTEN PERMISSION OF FORD PERFORMANCE PARTS.

- STEP 32:** Install gear shift lever boot over the shifter handle and slide into the reverse lockout and orientate the boot to its proper position. Evenly tighten the (3) set screws until shifter boot assembly is secured. **DO NOT OVERTIGHTEN.** Clip the gear shift lever boot securely in place into the center console.



NOTE: STEPS (33-37) WILL AID IN THE INSTALLATION OF EITHER THE PRODUCTION SHIFTER KNOB OR THE FORD PERFORMANCE SHIFT KNOB (M-7213-MSVT) WHICH IS SOLD SEPERATLY

- STEP 33:** Thread the provided jam nut onto the shifter shaft. Start by setting the jam nut to (14mm) measured from the top of the shifter handle to the top of the nut.



NO PART OF THIS DOCUMENT MAY BE REPRODUCED WITHOUT PRIOR AGREEMENT AND WRITTEN PERMISSION OF FORD PERFORMANCE PARTS.

- STEP 34:** Thread the shifter knob onto the shifter handle until it meets the jam nut. Visually look at the shifter knob pattern orientation. Remove the knob and adjust the jam nut up or down in $\frac{1}{4}$ turn increments until orientation is satisfactory.
- STEP 35:** After satisfactory shift knob orientation is established, verify proper reverse lockout operation and functionality.
- STEP 36:** Remove shifter knob. Record the current measured distance from the top of the shifter handle to the top of the nut.
- STEP 37:** Remove the jam nut. Place Blue thread locking compound onto the shifter shaft threads just above your recorded jam nut measurement. Install the jam nut over the locking compound and set it at your recorded measurement. Allow locking compound to set up and install the shift knob.

