

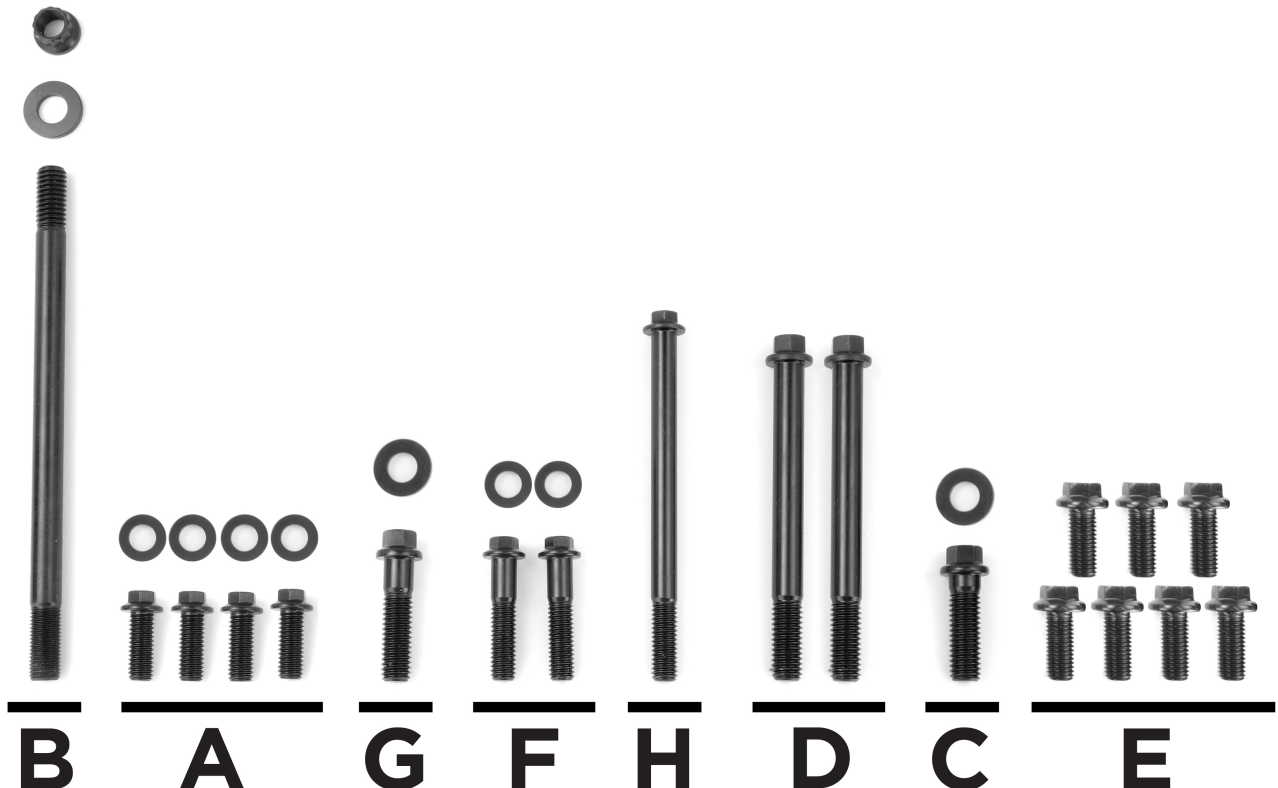

LRS-10313-K Instructions

1. Install **Stud "B"** into upper R/H hole location on the driver's side head. (See Figure 1)
2. Slide rear A/C bracket (LRS-9998927) over the **Stud "B"** using Hole #1 indicated in Figure 2
3. Install **Bolt "C"** through hole to mount the back bracket. (See Figure 2)
4. Install power steering pump to the P/S mounting bracket (LRS-9998926) using qty 3 of **Bolt "A"**.
5. Slide the top hole #2 of the power steering pump bracket assembly over **Stud "B"**. (See Figure 4)
6. Install Front A/C Mounting Bracket (LRS-9998929) over **Stud "B"** as well as the 3 water pump studs see Figure 4
"Note: the nuts that attach the A/C Mounting bracket to the water pump studs are included with the Water Pump Timing cover Hardware Kit LRS-8501BHDW that is sold separately"
7. Install QTY 1 of **Bolt "D"** into hole #3 indicated in Figure 4
8. Install Rear A/C Support Bracket (LRS-9998928) to Angled Flange on the Rear A/C bracket (LRS-9998927) Using QTY 2 of **Bolt "E"**
9. Use QTY 5 of **Bolt "E"** to finish mounting A/C compressor to Front A/C Mounting Bracket(LRS-9998929) and rear A/C support bracket (LRS-9998928) (See Figure 5)
10. Use QTY 1 of **Bolt "G"** to secure Alternator Bracket to Passenger's side head using Hole# 4 as shown on Figure 6
11. Use QTY 2 **Bolt "F"** to finish attaching alternator bracket to engine using bolt holes #5 as shown on Figure 6
12. QTY 1 of **Bolt "D"** will be used to mount lower alternator pivot in hole #6 (See Figure 6)
13. QTY 1 of **Bolt "H"** will be used to mount Smog Pump pivot in Hole #7 (See Figure 6)
14. Slide Rear Smog Pump Support bracket (LRS-9998930) over timing pointer stud and secure with Timing Pointer nut. "Note: Timing pointer hardware is included with Water pump timing cover hardware kit LRS-8501BHDW that is sold separately."
15. Use QTY 1 **Bolt "A"** to secure rear smog pump support bracket "LRS-9998930" to the back of the smog pump.



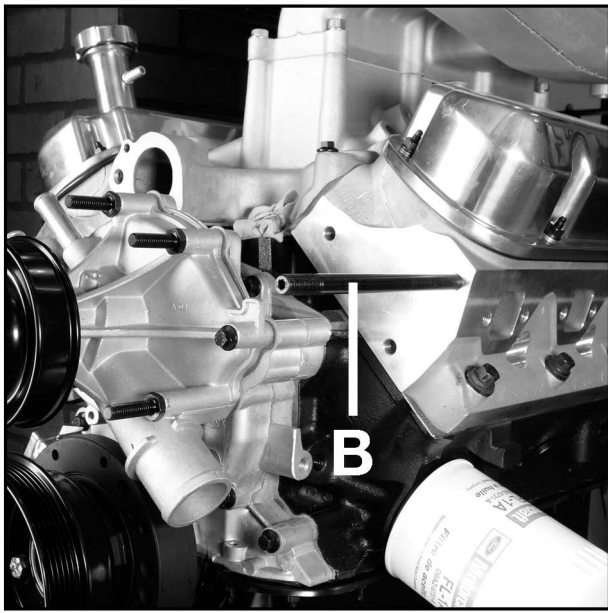

FIG.1

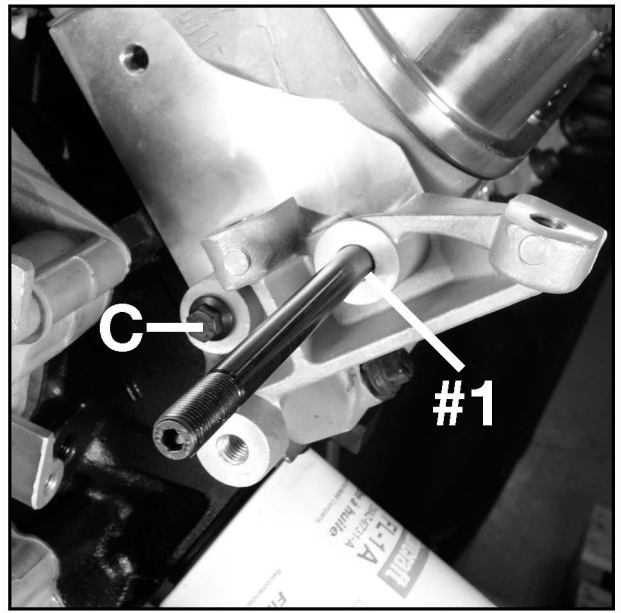

FIG.2

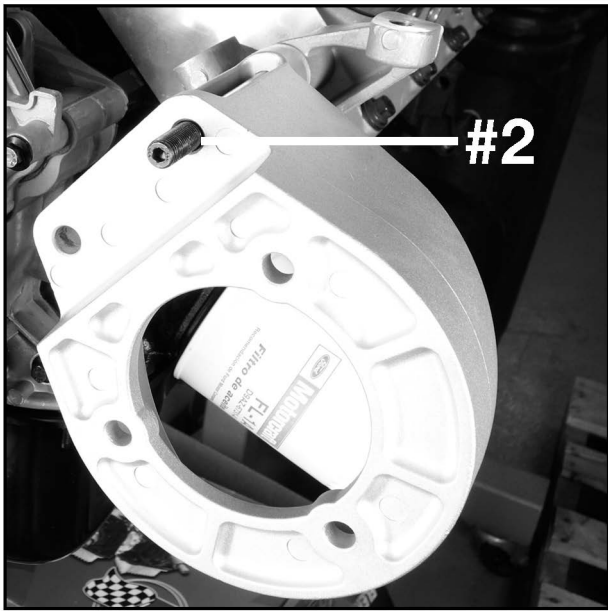

FIG.3

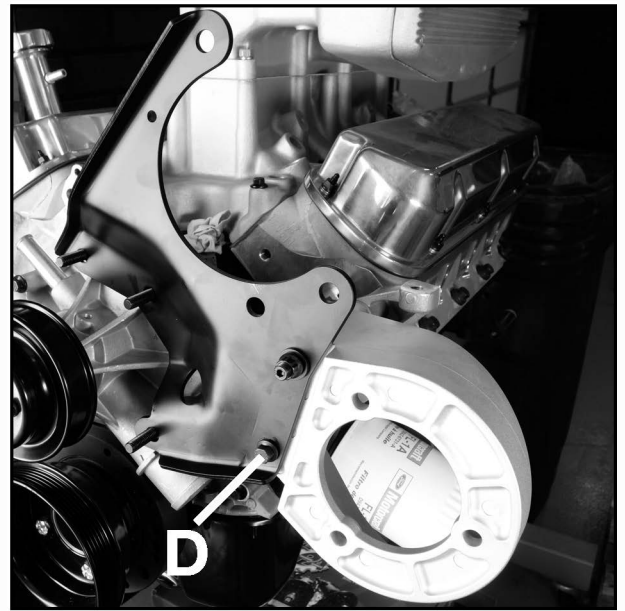

FIG.4

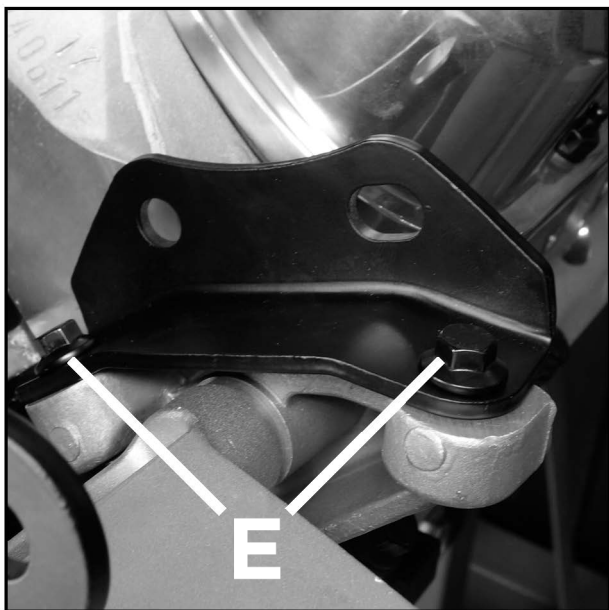

FIG.5

FIGURE 7

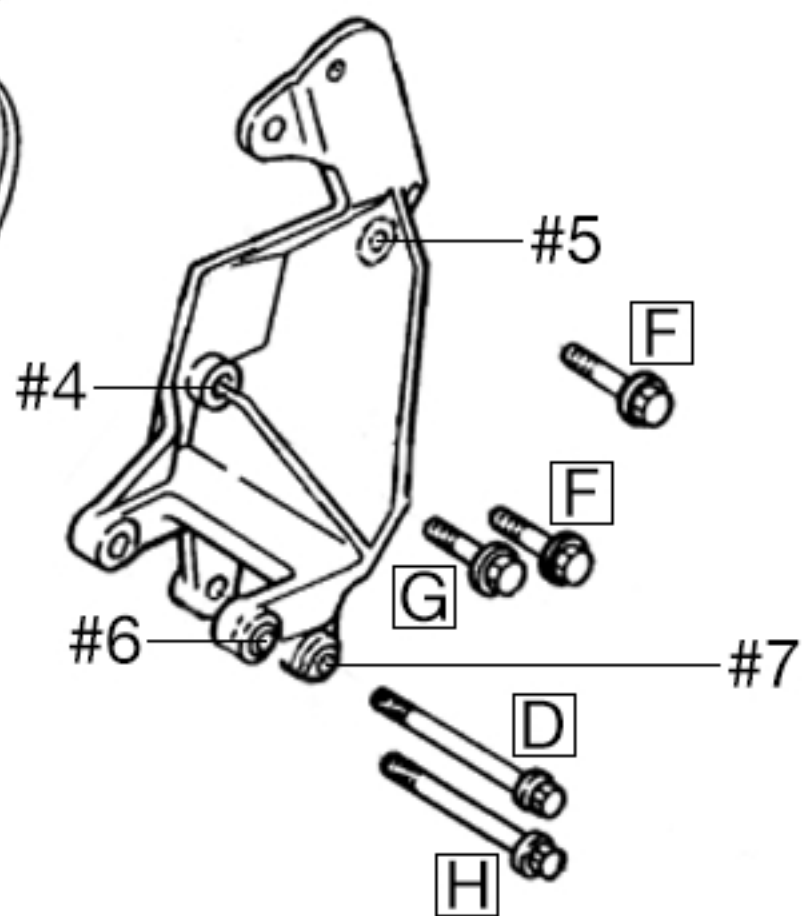
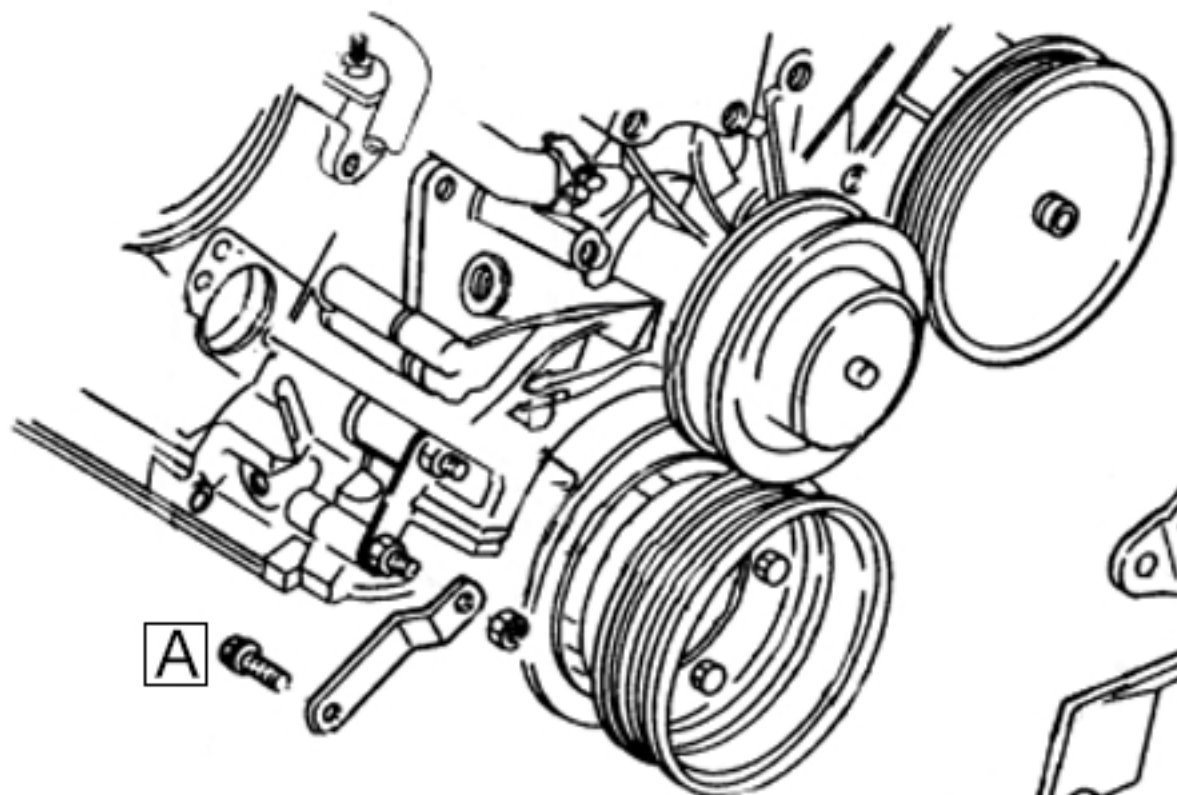
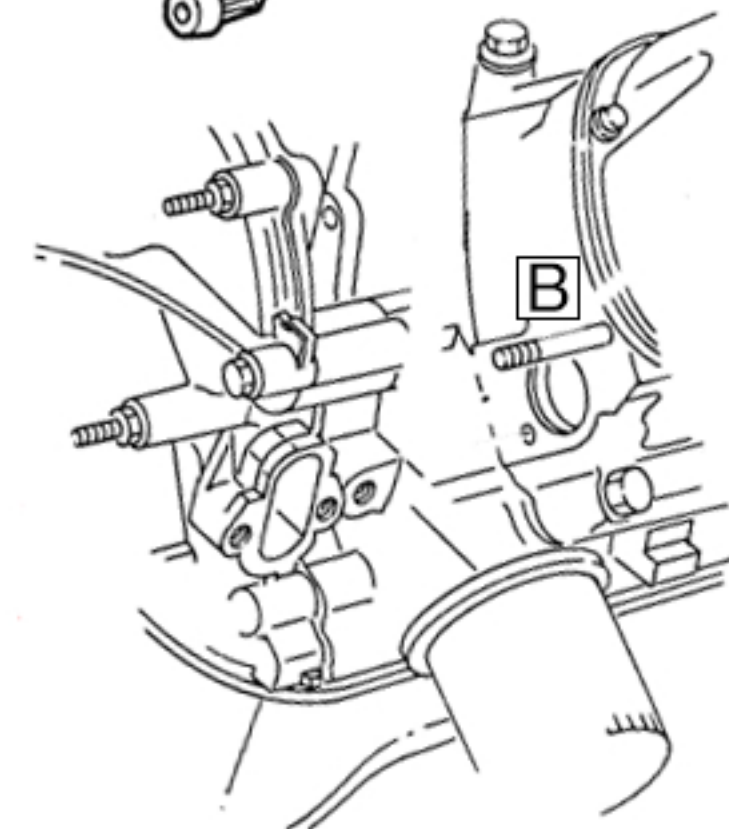
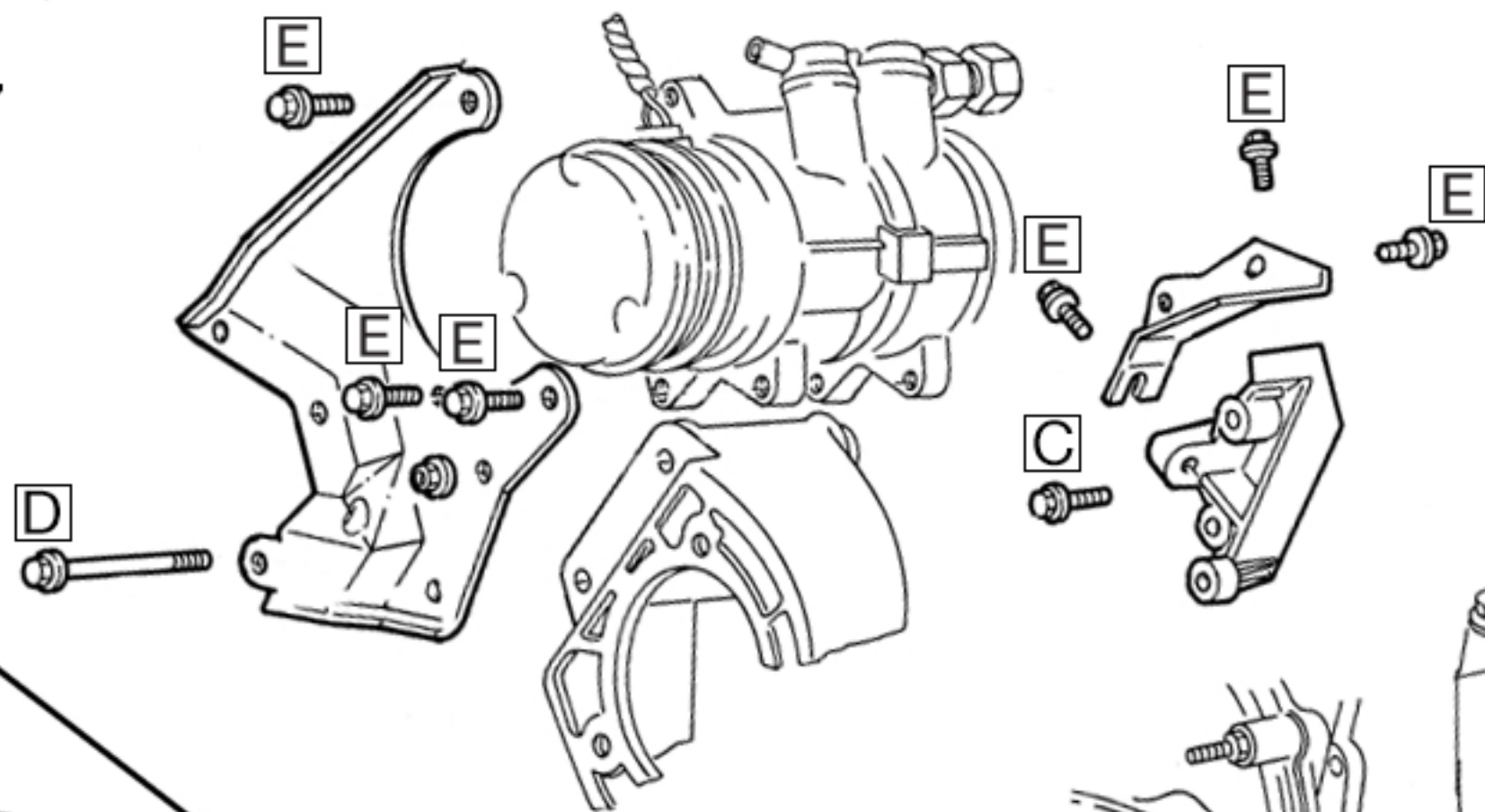

FIGURE 6