

2020 Ford Mustang V8-5.0L

Vehicle > Technical Service Bulletins

SAFETY RECALL 20S26 - IMAGE PROCESSING MODULE A CAMERA ALIGNMENT CALIBRATION



David J. Johnson
 Director
 Service Engineering Operations
 Ford Customer Service Division

Ford Motor Company
 P. O. Box 1904
 Dearborn, Michigan 48121

May 28, 2020

TO: All U.S. Ford and Lincoln Dealers

SUBJECT: NEW VEHICLE DEMONSTRATION / DELIVERY HOLD - Safety Recall 20S26
 Certain 2020 Model Year Mustang Vehicles
 Image Processing Module A Camera Alignment Calibration

AFFECTED VEHICLES

Vehicle	Model Year	Assembly Plant	Build Dates
Mustang	2020	Flat Rock	February 10, 2020 through February 11, 2020

Affected vehicles are identified in OASIS and FSA VIN Lists.

REASON FOR THIS SAFETY RECALL

In all of the affected vehicles, the Image Processing Module A (IPMA) camera may not be calibrated correctly. As a result, the following features could have degraded functionality during vehicle operation:

- Pre-Collision Assist (PCA)
- Adaptive Cruise Control (ACC)
- Lane Keeping System (LKS)
- Driver Alert
- Automatic High Beam Control (AHBC)

This condition may also prevent notifications to the driver that these features may not be functioning as intended. An incorrect IPMA camera calibration could compromise the effectiveness of the features to detect a frontal collision, maintain a safe distance from other vehicles, and detect lanes increasing the risk of an accident if the driver is relying on assistance from the system.

SERVICE ACTION

Before demonstrating or delivering any new in-stock vehicles involved in this recall, dealers are to reconfigure the IPMA by performing the Lane Departure Warning System (LDWS) camera alignment procedure using the Integrated Diagnostic Software (IDS) release 117.06 or higher.

This service must be performed on all affected vehicles at no charge to the vehicle owner.

OWNER NOTIFICATION MAILING SCHEDULE

Owner letters are expected to be mailed the week of June 15, 2020. Dealers should repair any affected vehicles that arrive at their dealerships, whether or not the customer has received a letter.

PLEASE NOTE:

Federal law requires dealers to complete this recall service before a new vehicle is delivered to the buyer or lessee. Violation of this requirement by a dealer could result in a civil penalty of up to \$21,000 per vehicle. Correct all vehicles in your new vehicle inventory before delivery.

© Copyright 2020 Ford Motor Company

ATTACHMENTS

Attachment I: Administrative Information
Attachment II: Labor Allowances and Parts Ordering Information
Attachment III: Technical Information
Owner Notification Letter

QUESTIONS & ASSISTANCE

For questions and assistance, contact the Special Service Support Center (SSSC) via the SSSC Web Contact Site. The SSSC Web Contact Site can be accessed through the Professional Technician Society (PTS) website using the SSSC link listed at the bottom of the OASIS VIN report screen or listed under the SSSC tab.

Sincerely,



David J. Johnson

© Copyright 2020 Ford Motor Company

ATTACHMENT I

Page 1 of 2

NEW VEHICLE DEMONSTRATION / DELIVERY HOLD - Safety Recall 20S26

Certain 2020 Model Year Mustang Vehicles
Image Processing Module A Camera Alignment Calibration

OASIS ACTIVATION

OASIS will be activated on May 28, 2020.

FSA VIN LISTS ACTIVATION

FSA VIN Lists will be available through <https://web.fsavinlists.dealerconnection.com> on May 28, 2020. Owner names and addresses will be available by June 23, 2020.

NOTE: Your FSA VIN Lists may contain owner names and addresses obtained from motor vehicle registration records. The use of such motor vehicle registration data for any purpose other than in connection with this recall is a violation of law in several states, provinces, and countries. Accordingly, you must limit the use of this listing to the follow-up necessary to complete this recall.

SOLD VEHICLES

- Ford has not issued instructions to stop selling/delivering or driving used vehicles under this safety recall. Owners should contact their dealer for an appointment to have their vehicles remedied as soon as practicable. Owners can continue to safely drive their vehicles.
- Immediately contact any of your affected customers whose vehicles are not on your VIN list but are identified in OASIS. Give the customer a copy of the Owner Notification Letter (when available) and schedule a service date.
- Correct other affected vehicles identified in OASIS which are brought to your dealership.
- Dealers are to prioritize repairs of customer vehicles over repairs of new and used vehicle inventory.

STOCK VEHICLES

- Correct all affected units in your new vehicle inventory before delivery.
- Use OASIS to identify any affected vehicles in your used vehicle inventory.

DEALER-OPERATED RENTAL VEHICLES

The Fixing America's Surface Transportation (FAST) Act law effective June 2016 prohibits a rental company from selling, renting or leasing vehicles subject to a safety or compliance recall. Please consult your legal counsel for legal advice.

TITLE BRANDED / SALVAGED VEHICLES

Affected title branded and salvaged vehicles are eligible for this recall.

OWNER REFUNDS

Refunds are not approved for this program.

RENTAL VEHICLES

Rental vehicles are not approved for this program.

© Copyright 2020 Ford Motor Company

ATTACHMENT I

Page 2 of 2

NEW VEHICLE DEMONSTRATION / DELIVERY HOLD - Safety Recall 20S26

Certain 2020 Model Year Mustang Vehicles
Image Processing Module A Camera Alignment Calibration

ADDITIONAL REPAIR (LABOR TIME AND/OR PARTS)

Additional repairs identified as necessary to complete the FSA should be managed as follows:

- For related damage and access time requirements, refer to the Warranty and Policy Manual / Section 6 – Ford & Lincoln Program Policies / General Information & Special Circumstances for FSA's / Related Damage.
- For vehicles within new vehicle bumper-to-bumper warranty coverage, no SSSC approval is required, although related damage must be on a separate repair line with the "Related Damage" radio button checked.
 - Ford vehicles – 3 years or 36,000 miles
- For vehicles outside new vehicle bumper-to-bumper warranty coverage, submit an Approval Request to the SSSC Web Contact Site prior to completing the repair.

CLAIMS PREPARATION AND SUBMISSION

- **Claim Entry:** Enter claims using Dealer Management System (DMS) or One Warranty Solution (OWS) online.
 - When entering claims, select claim type 31: Field Service Action. The FSA number 20S26 is the sub code.
 - For additional claims preparation and submission information, refer to the Recall and Customer Satisfaction Program (CSP) Repairs in the OWS User Guide.
- **Related Damage/Additional labor and/or parts:** Must be claimed as Related Damage on a separate repair line from the FSA with same claim type and sub code as described in Claim Entry above.

IMPORTANT: Click the Related Damage Indicator radio button.

© Copyright 2020 Ford Motor Company

ATTACHMENT II

Page 1 of 1

NEW VEHICLE DEMONSTRATION / DELIVERY HOLD - Safety Recall 20S26
Certain 2020 Model Year Mustang Vehicles
Image Processing Module A Camera Alignment Calibration**LABOR ALLOWANCES**

Description	Labor Operation	Labor Time
Perform the IPMA LDWS camera alignment calibration using IDS release 117.06 or higher.	20S26B	0.6 Hours

PARTS REQUIREMENTS / ORDERING INFORMATION

Parts are not required to complete this repair.

© Copyright 2020 Ford Motor Company

**CERTAIN 2020 MODEL YEAR MUSTANG VEHICLES — IMAGE PROCESSING
MODULE A CAMERA ALIGNMENT CALIBRATION****SERVICE PROCEDURE**

1. Connect a battery charger to the 12V battery.

NOTE: Verify that the negative cable of the charger is installed on a chassis or engine ground, and not the 12 volt battery negative terminal to prevent the battery saver mode from activating on the vehicle.

NOTE: Make sure the IDS computer does not enter sleep mode during Image Processing Module A (IPMA) camera alignment calibration.

2. Connect the Integrated Diagnostic Software (IDS) to the vehicles Data Link Connector (DLC) and identify the vehicle.
3. Select "Tool Box", then "Body", then "LDWS Camera Alignment" and then select the "Tick".
4. Select "Continue".
5. Read over and note the "Vehicle Condition, Drive Cycle, Route Planning and Outside Conditions" then select "Continue".
6. Turn the ignition to the ON position with the engine not running and select "OK".
7. When prompted with the question "Do you wish to keep these values" select "No" to reconfigure the wheel arch height measurement. See Figure 1.

NOTE: The wheel arch height measurements must be reconfigured. Failure to reconfigure the wheel arch height measurements will result in the IPMA camera to be misaligned.

Image Processing Module A IPMA Alignment

Wheel arch heights currently configured in the IPMA module

Left Front : 734 mm (28.9 in)

Right Front : 734 mm (28.9 in)

Do you wish to keep these values?

Yes No

2050A

FIGURE 1

CPR © 2020 FORD MOTOR COMPANY
DEARBORN, MICHIGAN 48121
05/2020

- 8. The front left and right wheel arch height measurements are required. Make sure the vehicle is parked on a level surface, at normal operating height and not overloaded, then select "Continue".
- 9. Measure and record the front wheel arch height measurements. See Figures 2 and 3.

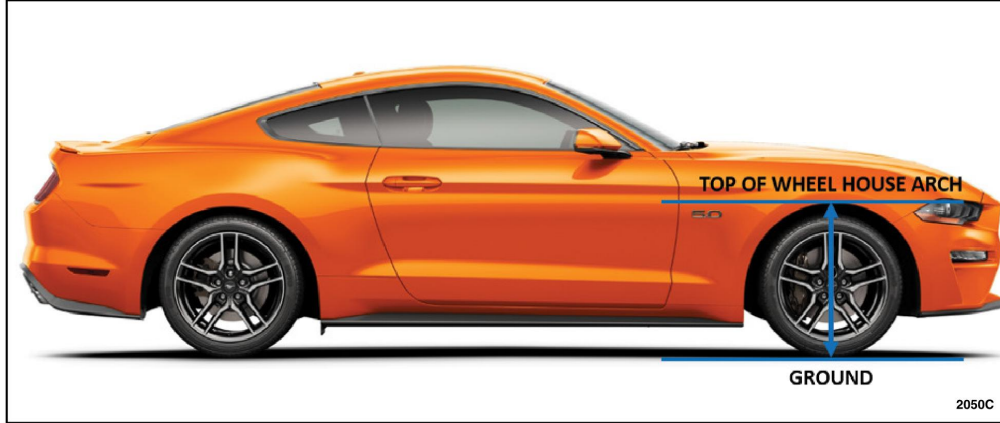

FIGURE 2

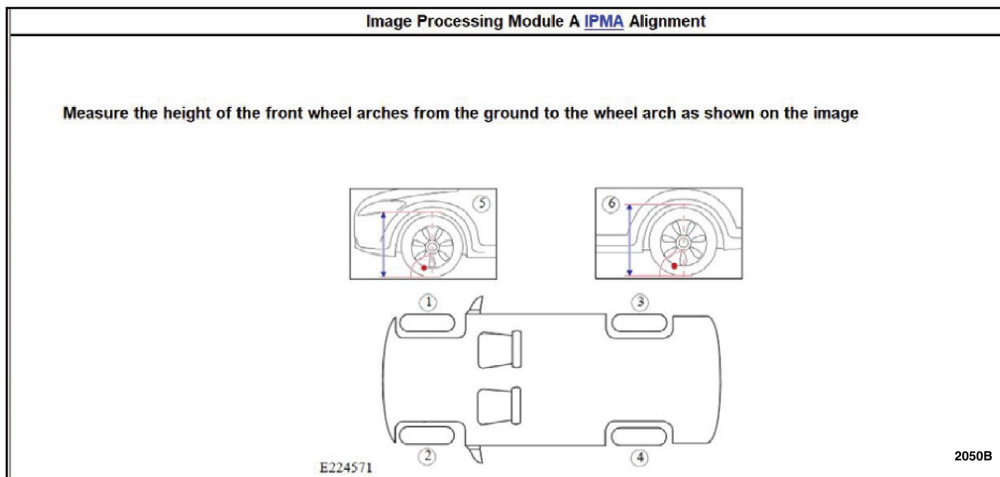

FIGURE 3



CPR © 2020 FORD MOTOR COMPANY
DEARBORN, MICHIGAN 48121
05/2020

10. Enter the measurements for the front wheel arch heights, then select "Ok". See Figure 4.

The screenshot shows a calibration interface with two input sections. The first section is labeled "Left Front" and contains the instruction "Enter the height of the left front wheel arch in millimeters" followed by a horizontal text input field. The second section is labeled "Right Front" and contains the instruction "Enter the height of the right front wheel arch in millimeters" followed by another horizontal text input field. To the right of these fields is a button labeled "OK". A black arrow points to the "OK" button. The text "2050D" is located in the bottom right corner of the screenshot.

FIGURE 4

11. Disconnect the battery charger and close the hood.
12. Start the engine, do not key off the vehicle until calibration is complete. Select "Ok".
13. Begin the road test on a road with visible lane markers and select "Continue" to begin the calibration. See Figure 5.

The screenshot displays a text-based instruction screen. It begins with the text "The IPMA is in alignment mode:". This is followed by a bulleted list of instructions: "Drive the vehicle on a road with visible lane markers. Drive in a steady manner over 64kph (40mph) avoiding lane crossing, excessive steering angle changes, or sudden changes in vehicle speed." and "Do not key off until the calibration is complete". Below the list, it says "Select Continue to monitor calibration completion progress". At the bottom right, there is a button labeled "Continue". A black arrow points to the "Continue" button. The text "2050F" is located in the bottom right corner of the screenshot.

FIGURE 5



CPR © 2020 FORD MOTOR COMPANY
DEARBORN, MICHIGAN 48121
05/2020

14. Once the calibration reaches 100% select "Ok". See Figure 6.

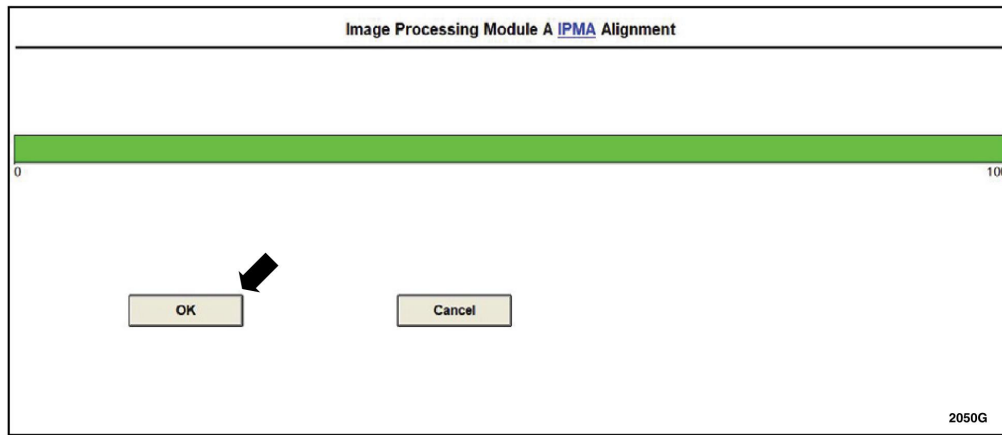

FIGURE 6

15. Procedure completed, select "Continue". See Figure 7.

NOTE: "Front Camera Malfunction - Service Required" popup message may not apply to this program.

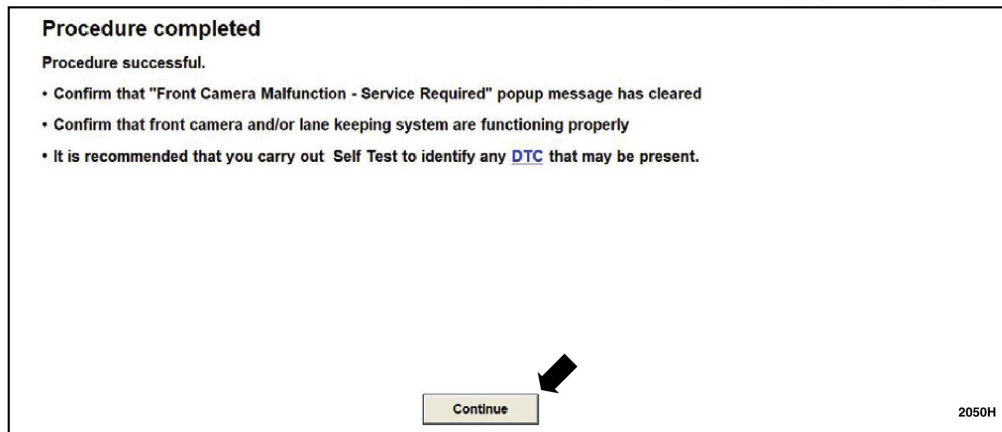

FIGURE 7

16. Check and clear any DTC's.

